

# Test Report

## Airtightness test of the vapour control layer "SIGA Majrex" system including connections

### Manufacturer: SIGA

Airtightness system: Surface sealing

Darmstadt 25.02.2017

Passive House Institute  
Dr. Wolfgang Feist  
Rheinstrasse 44/46  
64291 Darmstadt, Germany  
[www.passivehouse.com](http://www.passivehouse.com)

---

<b>Commissioned by:</b>	SIGA Cover AG Rüt mattstrasse 7 CH-6017 Ruswil Schweiz
<b>Product:</b>	<b>Airtightness system consisting of</b> <ol style="list-style-type: none"><li>1. SIGA Majrex Hygrobrid vapour control layer</li><li>2. SIGA Sicrall 60 single-sided adhesive tape</li><li>3. SIGA Fentrim 20 50/85 high-performance airtight tape with plastering zone</li></ol>
<b>Product name:</b>	SIGA Majrex
<b>Tested size:</b>	Metre rolls

---

## 1. Introduction

Airtightness across the surface is a central prerequisite for an effective airtightness concept. Airtightness of the building envelope is an essential element for its overall functioning, particularly in energy efficient buildings. This investigation took place under the most realistic possible boundary conditions within the framework of certification as a Passive House component in order to ensure that the tested products function in the installed state. In particular, the connection of the membrane to the typical adjacent materials was tested in the context of certification. With respect to the product system, this test examined the bonding of the membranes with each other and bonding with concrete and hard engineered wood panels (OSB in the present case), as well as the adhesive materials used.

## 2. Criteria

The values specified for Passive House certification of surface sealing products can be taken from Table 1 below:

**Table 1: Requirement classes for the certification of surface sealing products according to Passive House Institute specifications**

<b>Class</b>	<b>Air permeability per unit area @ 50 Pa [m<sup>3</sup>/(hm<sup>2</sup>)]</b>
phA	≤ 0.10
phB	≤ 0.18
phC	≤ 0.25

These apply for the overall performance of a product system specified by the client, consisting of several components.

In addition, comprehensible processing guidelines/instructions for use must be provided for installation of the product, on which the test setup will be based. These must be made available to all users.

Testing of moisture permeability and specific moisture values at different ambient humidity levels are not part of this test.

### **3. Material to be tested**

The required lengths of membranes and adhesive tapes for joining the different connection situations were supplied by the client.

In accordance with the manufacturer's instructions, the adhesive tape Sicrall® was used for overlapping of the vapour control membrane. This adhesive tape was also used for connections with OSB panels. Bonding to concrete was carried out using the adhesive tape Fentrim®. The use of these adhesive tapes and their application took place in accordance with the manufacturer's specification which are described in the instructions for use.

The following products were supplied by the client on 06.12.2016:

- SIGA Majrex (roll: width 1.5 m, length 50 m)
- SIGA Sicrall 60
- SIGA Fentrim 20 50/85
- Instructions for use for professional users of SIGA (September 2016 edition)

### **4. Setup for the membrane and connections**

The membrane roll was cut into two metre pieces which were clamped into the test apparatus across their full width so that they extended on all sides. For sealing, a frame which was identical in construction to the sub-frame of the test apparatus was placed on the apparatus. The frame and counter frames were each equipped with a 5 cm wide sealing surface which served as a support for the airtight membrane. The counter frame was tightened to a defined torque using screws and a torque wrench. Tension-free and uniform installation in the test stand was possible due to the even pressure of the counter frame.

For the connection to OSB or concrete, an OSB panel or a concrete slab was placed in the fixture provided for this purpose. After clamping the piece of membrane, this was cut out along the respective panel. The piece of membrane was thus "suspended in

the air" and surrounded the respective panel. Depending on the type of panel, either Sicral® (OSB panel) or Fentrim® (concrete slab) was used to join the membrane with the panel. Here it is important to ensure that the membrane is "suspended in the air" so that pressing the adhesive tape is only possible to a limited extent. This corresponds to the usual process e.g. when laying the membrane in the roof area.

Each test setup (membrane to membrane, membrane to OSB and membrane to concrete) was created and measured three times in order to minimise any influences from workers.

## 4.1 Membrane to membrane

The connection or overlapping of two pieces of membranes was carried out using the adhesive tape Sicral® in accordance with the manufacturer's instructions. For this, the pieces of membrane were overlapped by 10 cm and then the adhesive tape was applied equally on both pieces of membrane as described in the instructions for use. It must be kept in mind here that application of the tape must take place in a "suspended" manner, therefore pressing on of the adhesive tape is only possible to a limited extent.

## 4.2 Membrane to concrete

The adhesive tape Fentrim® was used for the membrane to concrete connection. This adhesive tape has a divided backing strip. First the narrow side was applied to the membrane and then the other side of the tape was applied to the concrete slab. The perforated edge can be plastered over in addition. This was not done for this test. The adhesive tapes were first applied to both long sides. The subsequently applied tapes at the two short sides overlap at the four corners with their full width.

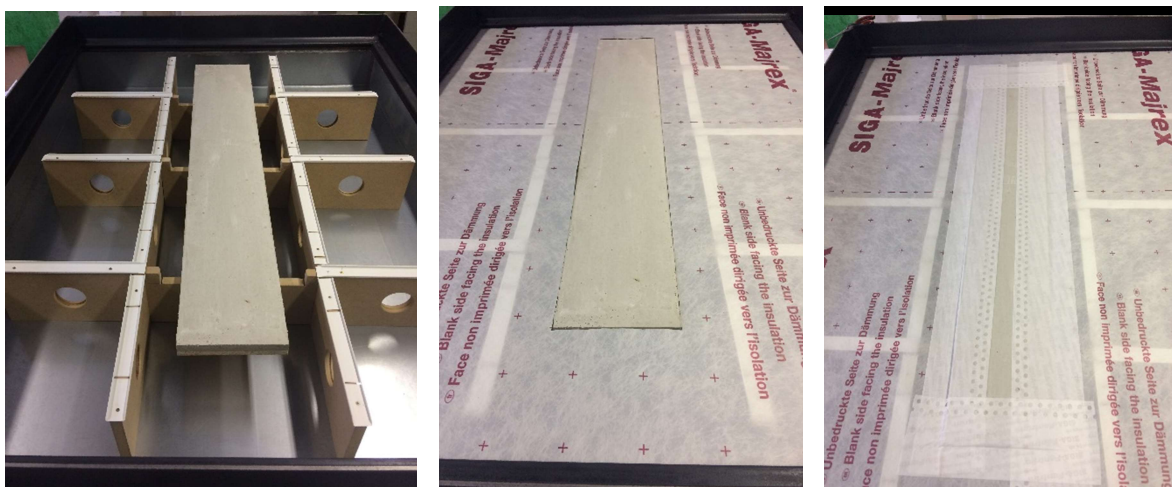

Fig. 1: Fixture for panels in the test apparatus with the concrete slab in position (left). The fixture for the panels simultaneously serves to support the membrane at

negative pressure. Centre: cut out membrane with the slab in position. Bonding of the concrete with the membrane using Fentrim® (right).

### 4.3 Membrane to OSB panel

The adhesive tape Sicrall® was used for connecting the OSB panel. Here too, the long sides were connected first. One half of the tape width was attached to the OSB panel and the other half was attached to the membrane. Finally the short sides were joined, overlapping with the full width of the adhesive tape.



Fig. 2: Cut out membrane with OSB panel (left). OSB panel joined to the membrane on all four sides using Sicrall® (right).

## 5. Test procedure

After setting up in the test stand and attaching the membrane, a measurement was carried out in compliance with DIN EN 12114. For this measurement, the following pressure stages were set for positive and negative pressure: 50, 100, 150, 200, 250, 300, 350 Pa. First the residual leakage of the test stand for all pressure stages was measured and documented for each measurement (reference measurement). For this, the test apparatus was closed using an airtight board. The infiltration air of the test stand determined thus was deducted from the result of the measurement afterwards.

In each measurement, the conveyed volume flow was measured and recorded for each individual pressure difference. With these pairs of measured values, it was possible to calculate the leakage coefficient **C** according to DIN 12114 Appendix B.

From the two series of reference measurements and the two series of actual measurements, linear equalising functions were determined through a regression analysis. After deducting the leakage of the test stand itself (reference measurement), the leakage flow was determined for the reference pressure difference of 50 Pa as an average value of the results from the series of negative and positive pressure measurements. This value is divided by the sample area in order to obtain the specific leakage flow per square metre. The free area of the sample is 1.72 m<sup>2</sup> or 1.48 m<sup>2</sup> with deduction of the cut-out for the OSB panel or concrete slab.

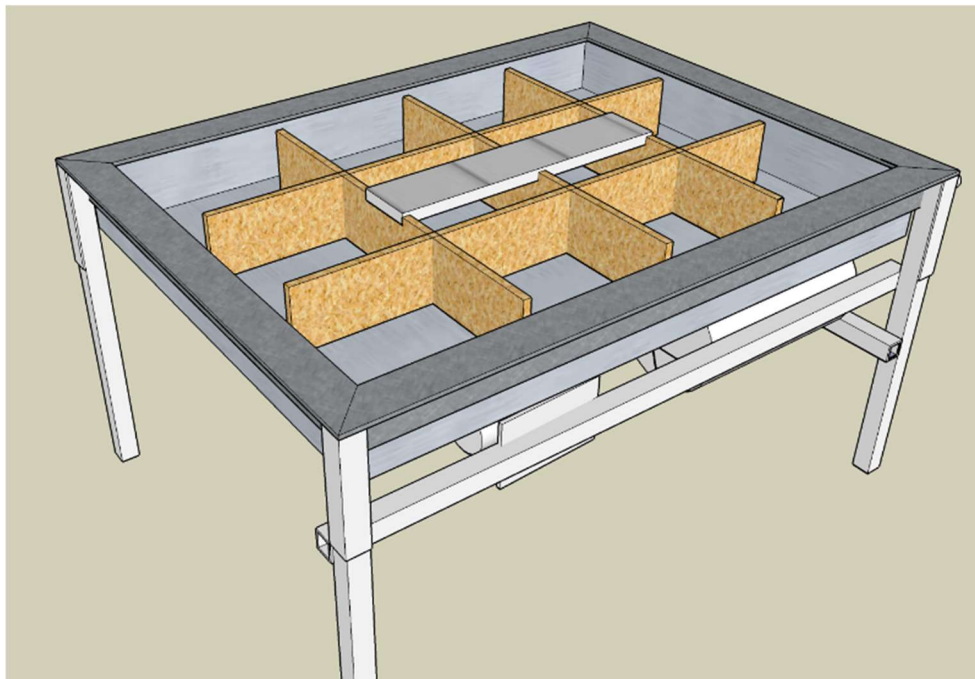

**Fig. 3:** Sketch of the test apparatus with a fixture for the respective panels

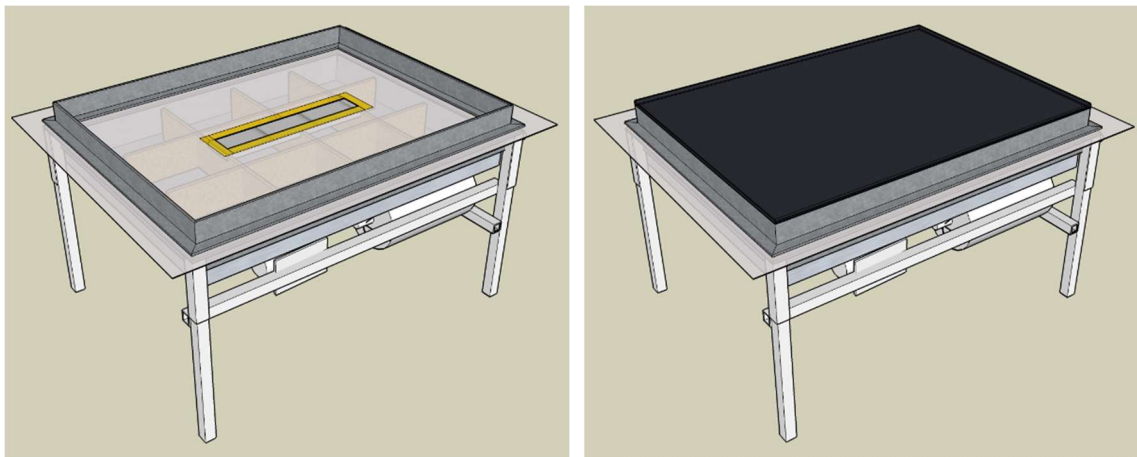

**Fig. 4:** Sketch of the test apparatus with the clamped membrane and inserted panel (left) which is joined to the membrane with adhesive tape (yellow). Test apparatus sealed with the cover panel for determining the test stand leakage (right).



**Fig. 5:** Test apparatus with clamped membrane (membrane to membrane bonding using Sicrall)

The measurements of the examined airtightness system took place in the time period 02.01.2017 to 27.01.2017.

## 6. Test results

The test results are shown in the following tables and figures, sorted according to the connection methods. The requirement classes for the certification of surface sealing systems are additionally entered in the diagrams.

### 6.1 Test with membrane

<b>Connection to</b>	
Membrane on its own	X
Membrane to membrane	
Membrane to OSB	
Membrane to concrete	

**Table 2: Test results of the three measurements with the membrane without any connection**

examined area	1,72 m <sup>2</sup>
---------------	---------------------

Majrex #1

Pressure stages	Pa	50	100	150	200	250	300	350
total volume flow	m <sup>3</sup> /h	0,05	0,07	0,09	0,11	0,12	0,14	0,15
test stand leakage	m <sup>3</sup> /h	0,05	0,07	0,09	0,11	0,12	0,14	0,15
specific air volume flow	m <sup>3</sup> /h	0,00	0,00	0,00	0,00	0,00	0,00	0,00
leakage volume flow based on area	m <sup>3</sup> /(h m <sup>2</sup> )	0,00	0,00	0,00	0,00	0,00	0,00	0,00

Majrex #2

total volume flow	m <sup>3</sup> /h	0,04	0,07	0,09	0,10	0,12	0,14	0,15
test stand leakage	m <sup>3</sup> /h	0,04	0,07	0,09	0,10	0,12	0,13	0,15
specific air volume flow	m <sup>3</sup> /h	0,00	0,00	0,00	0,00	0,00	0,00	0,00
leakage volume flow based on area	m <sup>3</sup> /(h m <sup>2</sup> )	0,00	0,00	0,00	0,00	0,00	0,00	0,00

Majrex #3

total volume flow	m <sup>3</sup> /h	0,04	0,06	0,08	0,10	0,11	0,12	0,14
test stand leakage	m <sup>3</sup> /h	0,04	0,06	0,08	0,10	0,11	0,12	0,14
specific air volume flow	m <sup>3</sup> /h	0,00	0,00	0,00	0,00	0,00	0,00	0,00
leakage volume flow based on area	m <sup>3</sup> /(h m <sup>2</sup> )	0,00	0,00	0,00	0,00	0,00	0,00	0,00

Average

Q50 (PHI - assessment) **0,00** m<sup>3</sup>/(h m<sup>2</sup>)

resulting in an airtightness class of **A** according to PHI

Q50 ≤ 0,1

In the following three diagrams with double logarithmic representation of the axis, the ascertained measured values are not recognisable because these are smaller than the smallest depicted y-axis value.



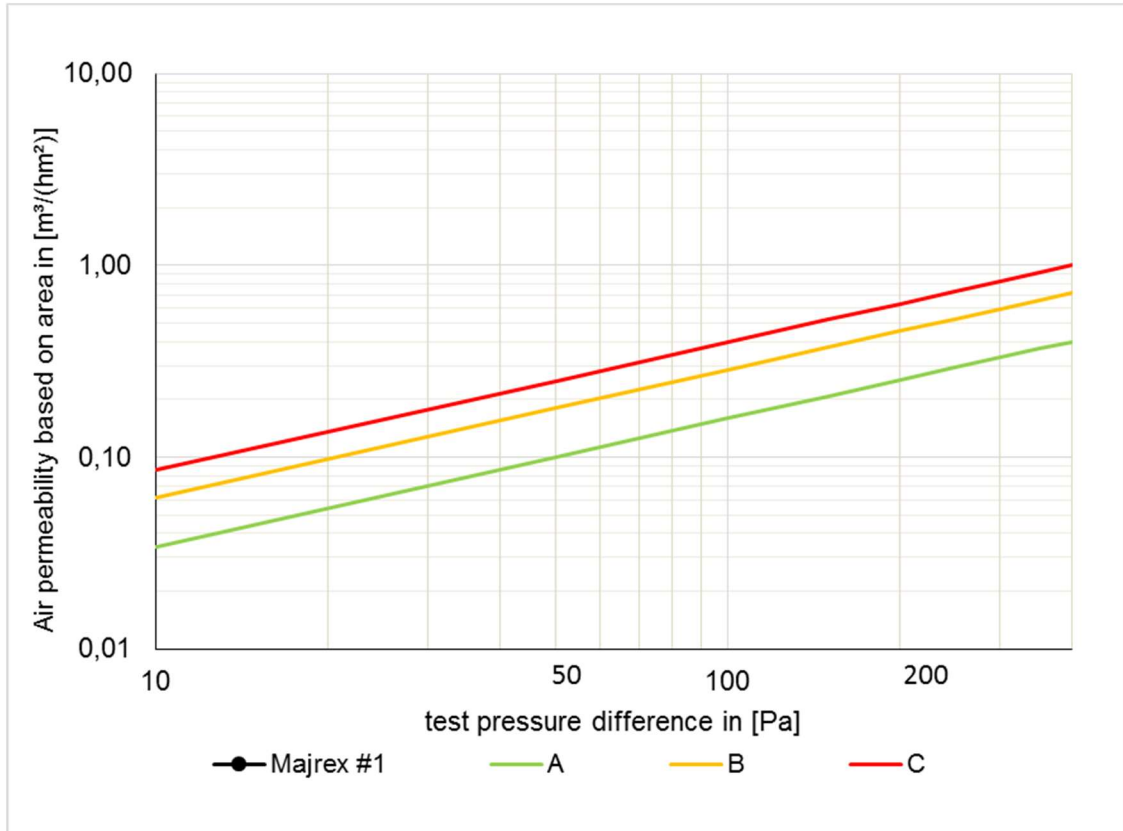

Fig. 6: Series of measurements for the sample "SIGA Majrex 1" (membrane on its own). The certificate classes A to C according to the PHI are entered in addition.

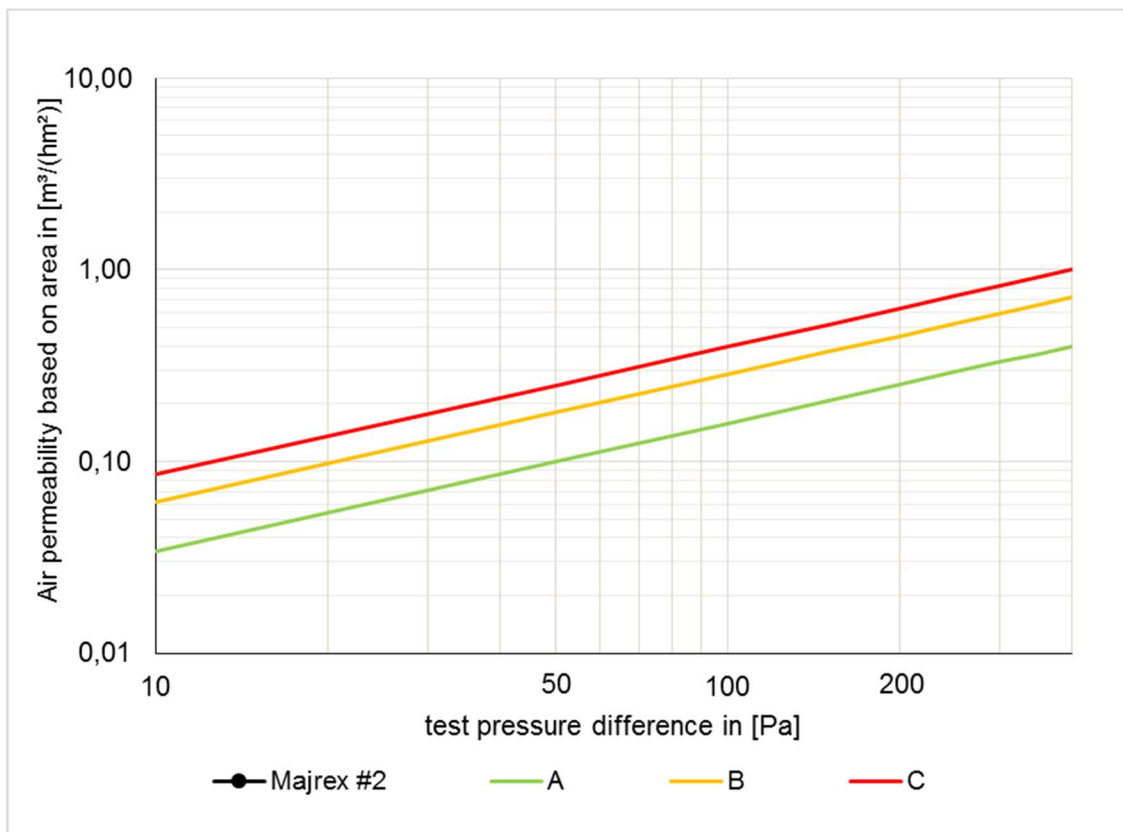

Fig. 7: Series of measurements for the sample "SIGA Majrex 2" (membrane on its own). The certificate classes A to C according to the PHI are entered in addition.

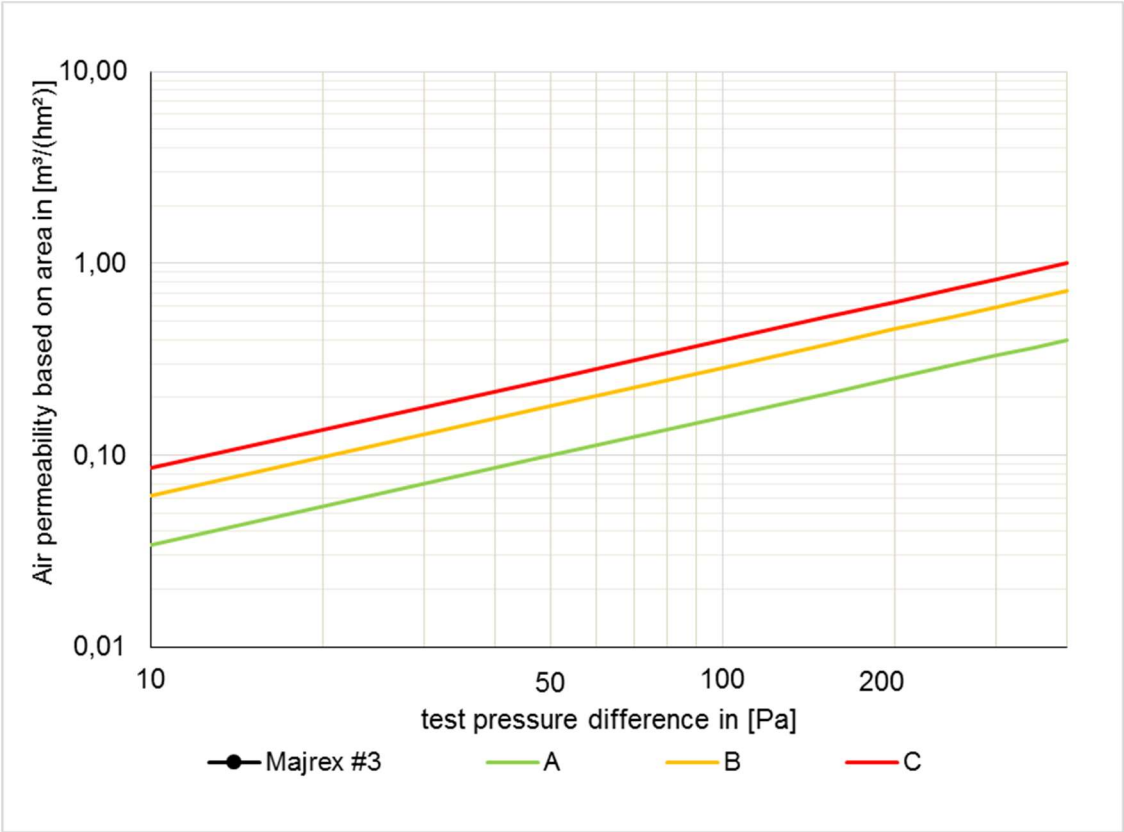

Fig. 8: Series of measurements for the sample "SIGA Majrex 3" (membrane on its own). The certificate classes A to C according to the PHI are entered in addition.

## 6.2 Membrane to membrane

Connection to	
Membrane on its own	
Membrane to membrane	x
Membrane to OSB	
Membrane to concrete	

**Table 3: Test results of the three measurements with the membrane joined to the membrane using Sicral<sup>®1</sup>**

examined area	1,72 m <sup>2</sup>
---------------	---------------------

Majrex to Majrex #1 bonded using Sicral

Pressure stages	Pa	50	100	150	200	250	300	350
total volume flow	m <sup>3</sup> /h	0,04	0,06	0,08	0,10	0,11	0,13	0,14
test stand leakage	m <sup>3</sup> /h	0,04	0,06	0,07	0,09	0,10	0,12	0,13
specific air volume flow	m <sup>3</sup> /h	0,00	0,00	0,01	0,01	0,01	0,01	0,01
leakage volume flow based on area	m <sup>3</sup> /(h m <sup>2</sup> )	0,00	0,00	0,00	0,00	0,00	0,01	0,01

Majrex to Majrex #2

total volume flow	m <sup>3</sup> /h	0,12	0,17	0,20	0,23	0,25	0,27	0,30
test stand leakage	m <sup>3</sup> /h	0,04	0,06	0,08	0,10	0,11	0,12	0,13
specific air volume flow	m <sup>3</sup> /h	0,08	0,10	0,12	0,13	0,14	0,15	0,16
leakage volume flow based on area	m <sup>3</sup> /(h m <sup>2</sup> )	0,05	0,06	0,07	0,08	0,08	0,09	0,09

Majrex to Majrex #3

total volume flow	m <sup>3</sup> /h	0,09	0,14	0,18	0,21	0,23	0,26	0,28
test stand leakage	m <sup>3</sup> /h	0,04	0,06	0,08	0,10	0,11	0,12	0,13
specific air volume flow	m <sup>3</sup> /h	0,05	0,08	0,09	0,11	0,12	0,14	0,15
leakage volume flow based on area	m <sup>3</sup> /(h m <sup>2</sup> )	0,03	0,04	0,05	0,06	0,07	0,08	0,09

Average

Q50 (PHI - assessment) **0,03** m<sup>3</sup>/(h m<sup>2</sup>)

resulting in an airtightness class of **A** according to PHI

Q50 ≤ 0,1

<sup>1</sup> The differences are due to rounding

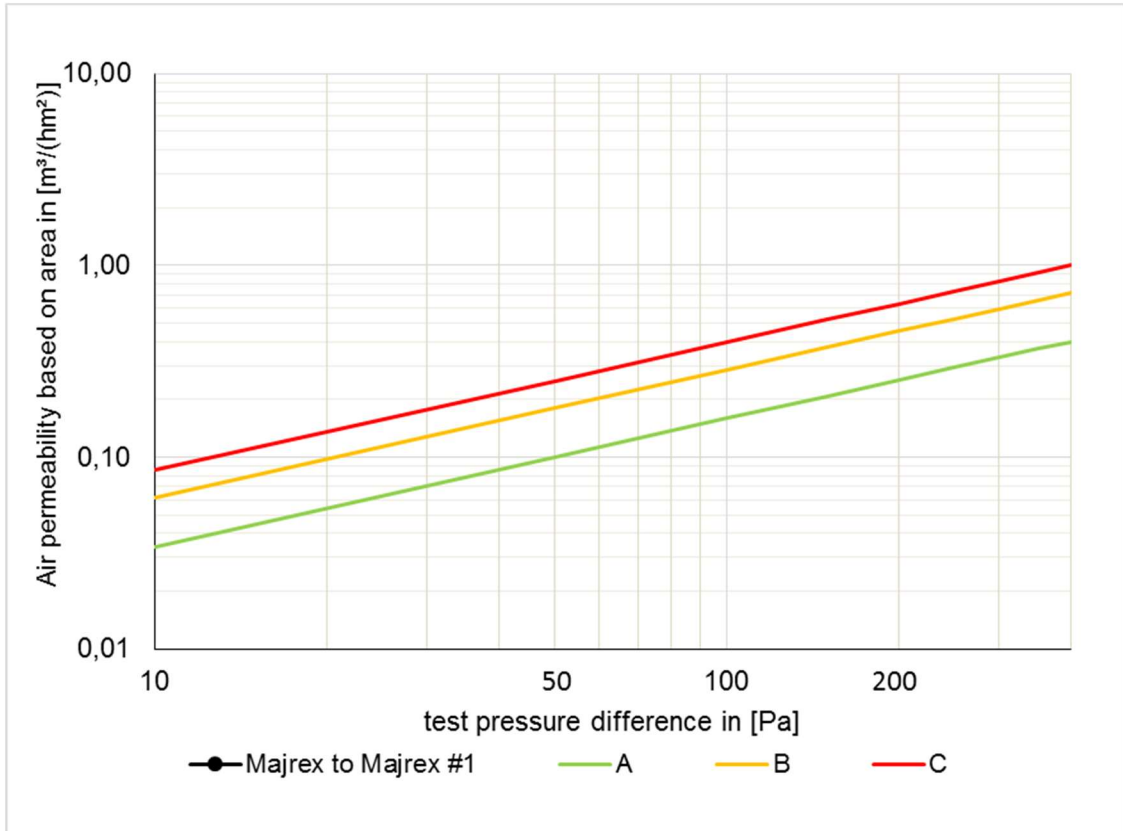

Fig. 9: Series of measurements for the sample "SIGA Majrex to SIGA Majrex #1". The certificate classes A to C according to the PHI are entered in addition

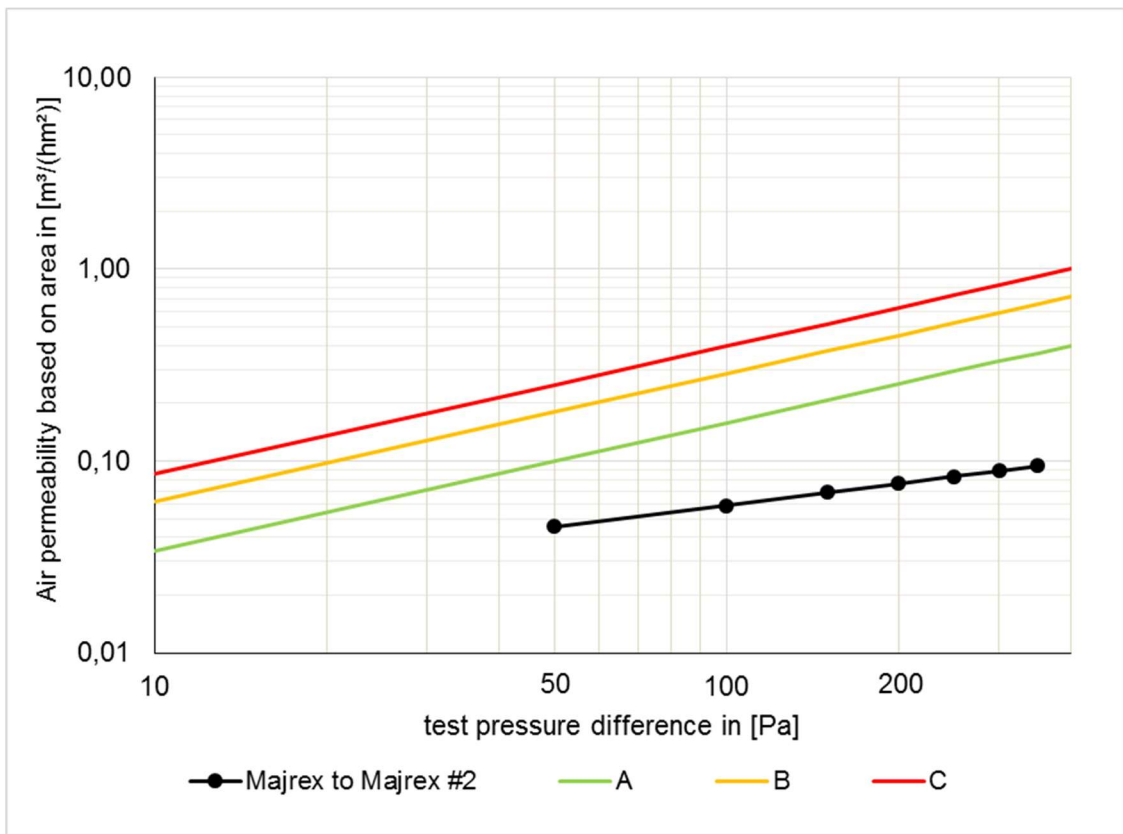

Fig. 10: Series of measurements for the sample "SIGA Majrex to SIGA Majrex #2". The certificate classes A to C according to the PHI are entered in addition.

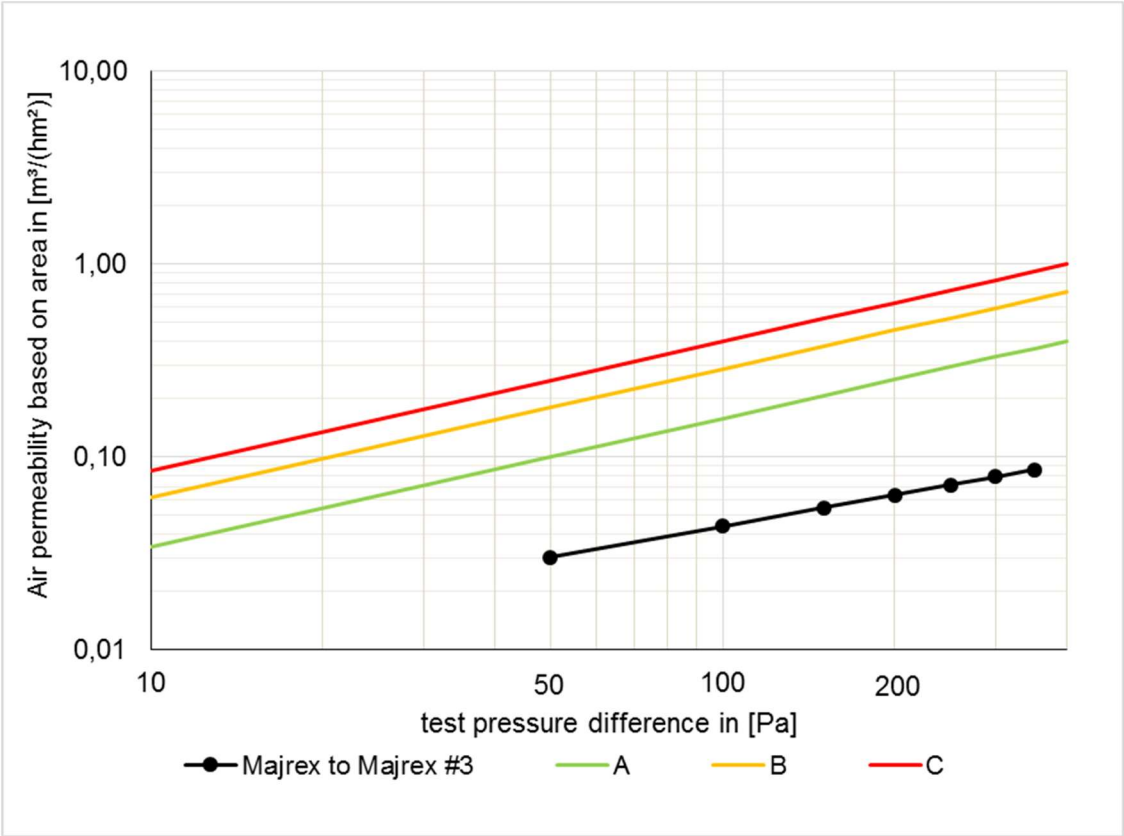

Fig. 11: Series of measurements for the sample "SIGA Majrex to SIGA Majrex #3". The certificate classes A to C according to the PHI are entered in addition.

### 6.3 Membrane to OSB panel

Connection to	
Membrane on its own	
Membrane to membrane	
Membrane to OSB	X
Membrane to concrete	

**Table 4: Test results of the three measurements with the membrane joined to the OSB panel using Sicral<sup>®2</sup>**

examined area	1,48 m <sup>2</sup>
---------------	---------------------

Majrex to OSB #1 bonded using Sicral

Pressure stages	Pa	50	100	150	200	250	300	350
total volume flow	m <sup>3</sup> /h	0,06	0,10	0,14	0,17	0,20	0,22	0,25
test stand leakage	m <sup>3</sup> /h	0,04	0,06	0,08	0,10	0,11	0,12	0,13
specific air volume flow	m <sup>3</sup> /h	0,02	0,03	0,05	0,07	0,08	0,10	0,11
leakage volume flow based on area	m <sup>3</sup> /(h m <sup>2</sup> )	0,01	0,02	0,03	0,04	0,05	0,07	0,08

Majrex to OSB #2

total volume flow	m <sup>3</sup> /h	0,06	0,10	0,13	0,16	0,19	0,22	0,25
test stand leakage	m <sup>3</sup> /h	0,05	0,07	0,09	0,10	0,11	0,13	0,14
specific air volume flow	m <sup>3</sup> /h	0,01	0,03	0,05	0,07	0,09	0,12	0,15
leakage volume flow based on area	m <sup>3</sup> /(h m <sup>2</sup> )	0,01	0,02	0,03	0,05	0,06	0,08	0,10

Majrex to OSB #3

total volume flow	m <sup>3</sup> /h	0,06	0,10	0,14	0,18	0,22	0,26	0,30
test stand leakage	m <sup>3</sup> /h	0,04	0,06	0,08	0,09	0,11	0,12	0,13
specific air volume flow	m <sup>3</sup> /h	0,02	0,04	0,06	0,09	0,12	0,15	0,19
leakage volume flow based on area	m <sup>3</sup> /(h m <sup>2</sup> )	0,01	0,02	0,04	0,06	0,08	0,10	0,13

Average

Q50 (PHI - assessment) **0,01** m<sup>3</sup>/(h m<sup>2</sup>)

resulting in an airtightness class of **A** according to PHI

Q50 ≤ 0,1

<sup>2</sup> The differences are due to rounding

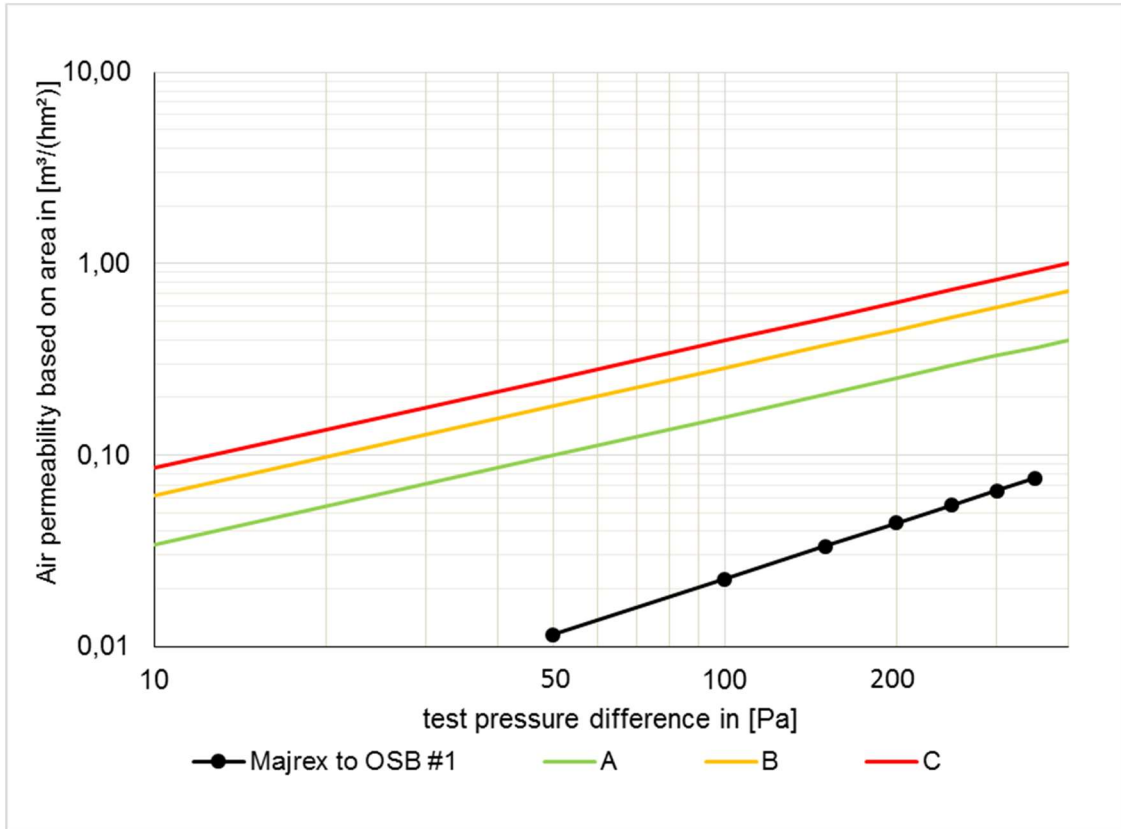

Fig. 12: Series of measurements for the sample "SIGA Majrex to OSB panel #1". The certificate classes A to C according to the PHI are entered in addition.

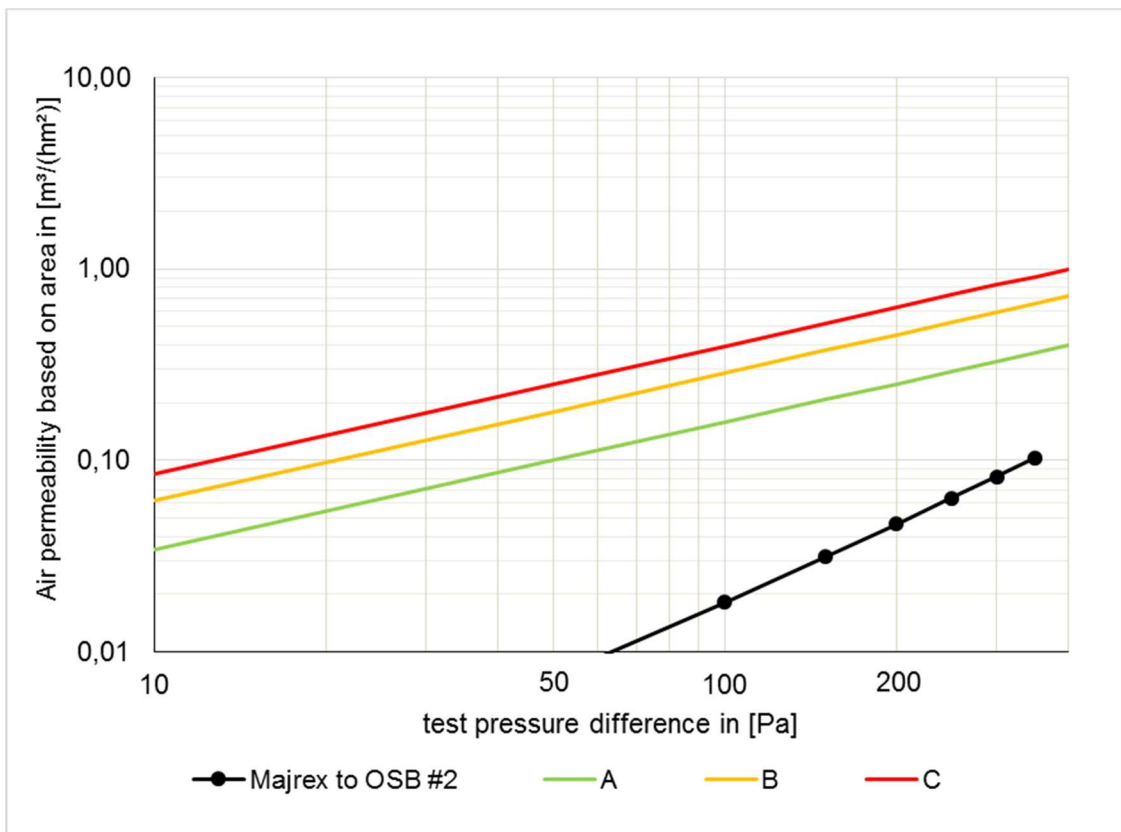

Fig. 13: Series of measurements for the sample "SIGA Majrex to OSB panel #2". The certificate classes A to C according to the PHI are entered in addition.

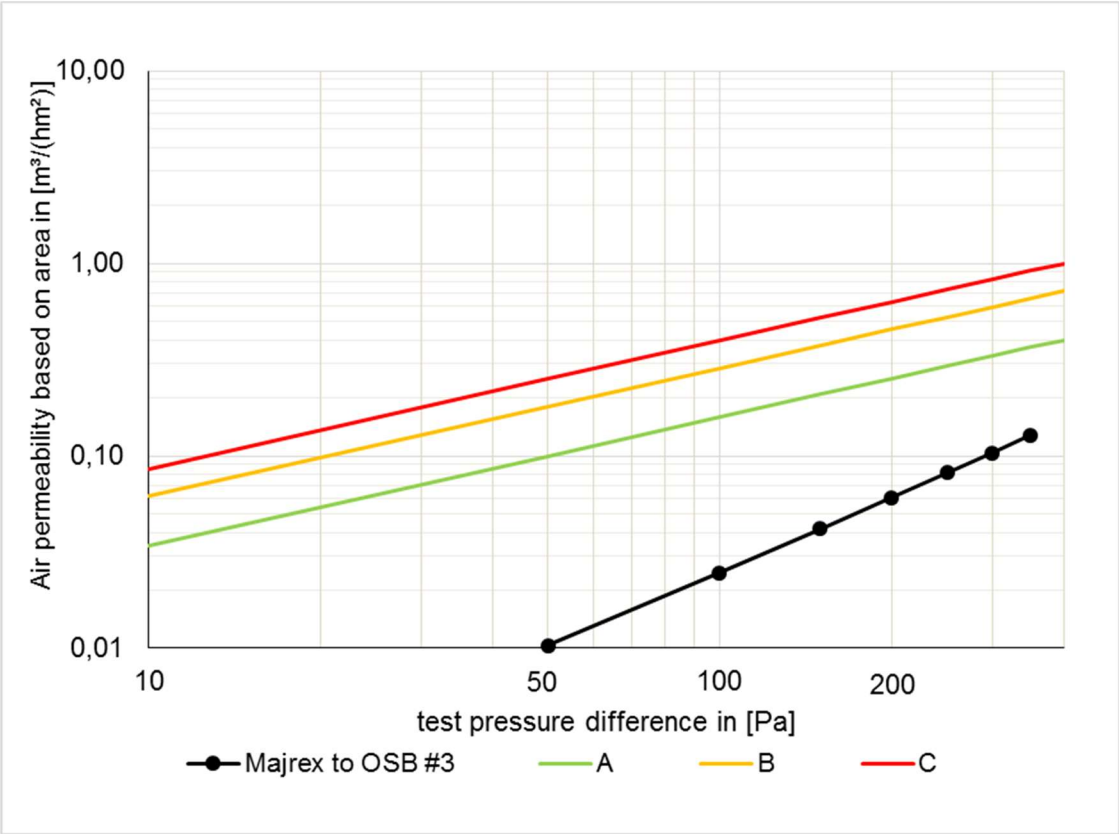

Fig. 14: Series of measurements for the sample "SIGA Majrex to OSB panel #3". The certificate classes A to C according to the PHI are entered in addition.



## 6.4 Membrane to concrete slab

Connected to	
Membrane on its own	
Membrane to Membrane	
Membrane to OSB	
Membrane to concrete	X

**Table 5: Test results of the three measurements with the membrane joined to the concrete slab using Fentrim®<sup>3</sup>**

examined area	1,48 m <sup>2</sup>
---------------	---------------------

Majrex to concrete #1 bonded using Fentrim 20 50/85

Pressure stages	Pa	50	100	150	200	250	300	350
total volume flow	m <sup>3</sup> /h	0,07	0,11	0,15	0,18	0,21	0,24	0,26
test stand leakage	m <sup>3</sup> /h	0,04	0,06	0,08	0,09	0,11	0,12	0,13
specific air volume flow	m <sup>3</sup> /h	0,03	0,05	0,07	0,09	0,11	0,12	0,14
leakage volume flow based on area	m <sup>3</sup> /(h m <sup>2</sup> )	0,02	0,04	0,05	0,06	0,07	0,08	0,09

Majrex to concrete #2

total volume flow	m <sup>3</sup> /h	0,08	0,14	0,19	0,23	0,28	0,32	0,36
test stand leakage	m <sup>3</sup> /h	0,05	0,07	0,09	0,10	0,11	0,13	0,14
specific air volume flow	m <sup>3</sup> /h	0,03	0,06	0,10	0,13	0,16	0,19	0,22
leakage volume flow based on area	m <sup>3</sup> /(h m <sup>2</sup> )	0,02	0,04	0,06	0,09	0,11	0,13	0,15

Majrex to concrete #3

total volume flow	m <sup>3</sup> /h	0,05	0,09	0,12	0,15	0,17	0,19	0,22
test stand leakage	m <sup>3</sup> /h	0,04	0,07	0,08	0,10	0,11	0,12	0,14
specific air volume flow	m <sup>3</sup> /h	0,01	0,02	0,03	0,05	0,06	0,07	0,09
leakage volume flow based on area	m <sup>3</sup> /(h m <sup>2</sup> )	0,01	0,02	0,02	0,03	0,04	0,05	0,06

Average

Q50 (PHI - assessment) **0,02** m<sup>3</sup>/(h m<sup>2</sup>)

resulting in an airtightness class of **A** according to PHI

Q50 ≤ 0,1

<sup>3</sup> The differences are due to rounding

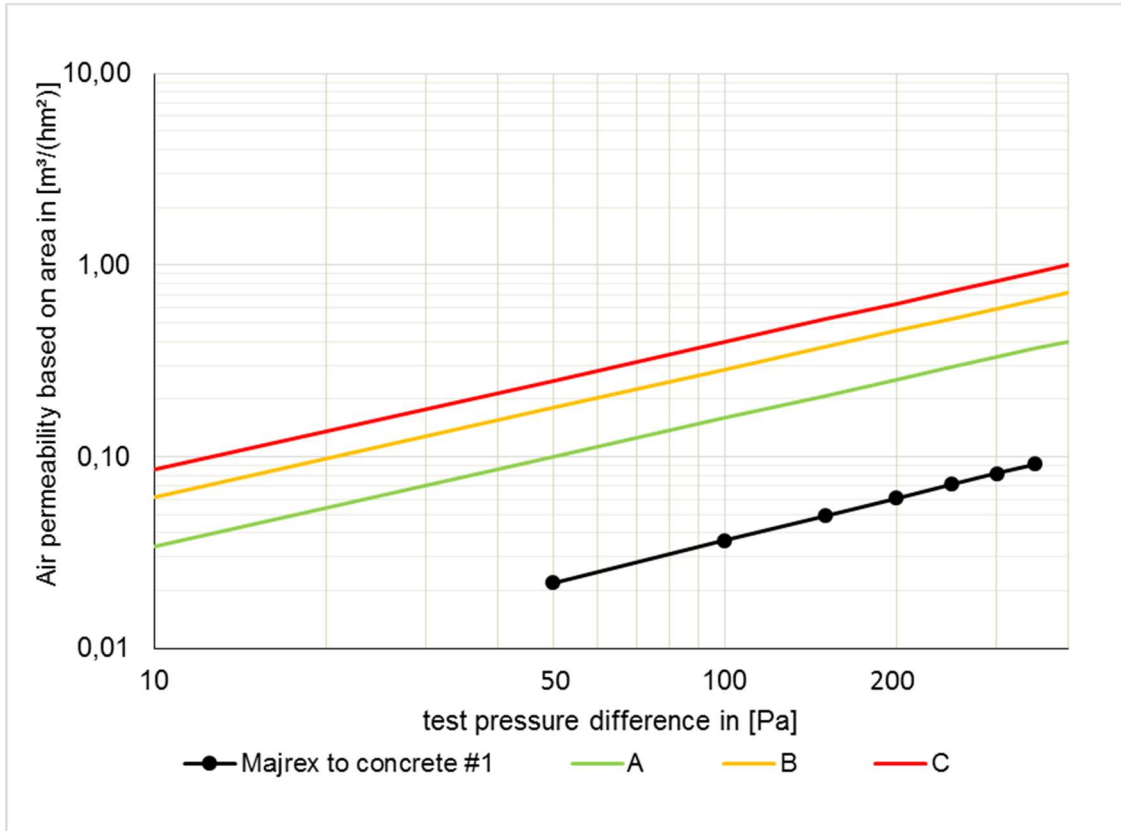

Fig. 15: Series of measurements for the sample "SIGA Majrex to concrete slab #1". The certificate classes A to C according to the PHI are entered in addition.

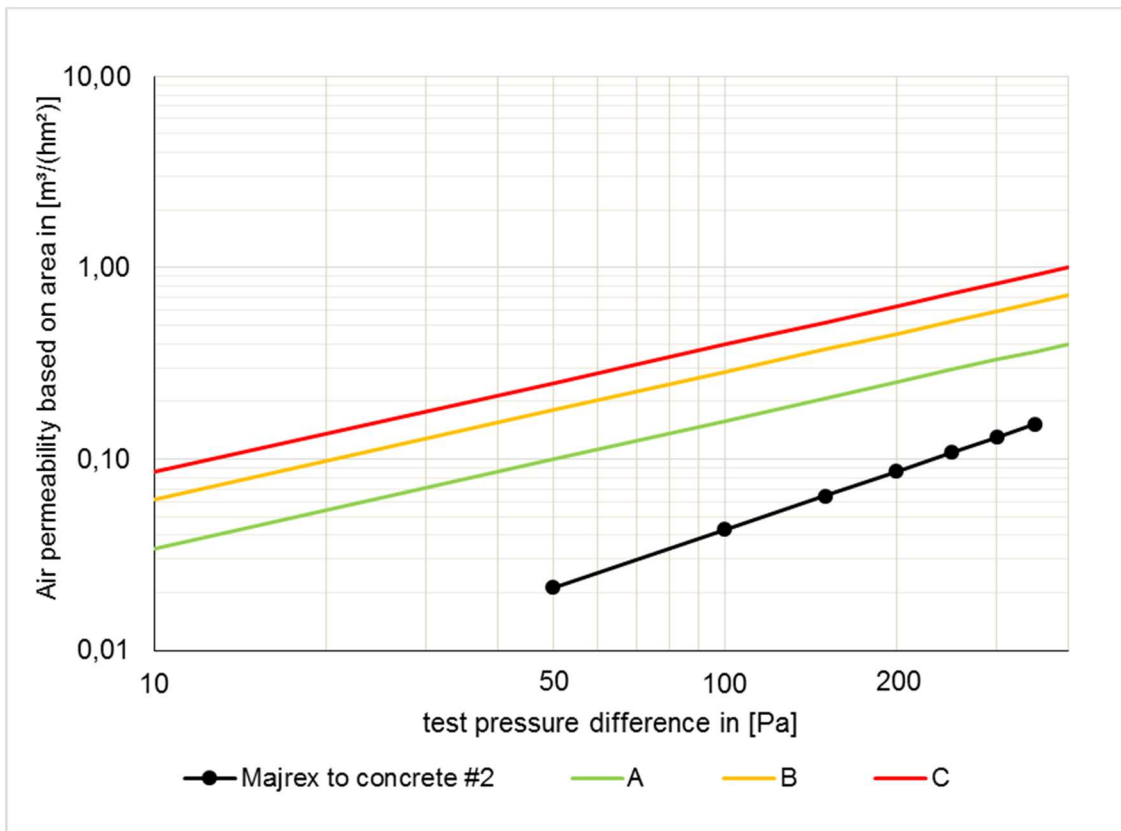

Fig. 16: Series of measurements for the sample "SIGA Majrex to concrete slab #2". The certificate classes A to C according to the PHI are entered in addition.

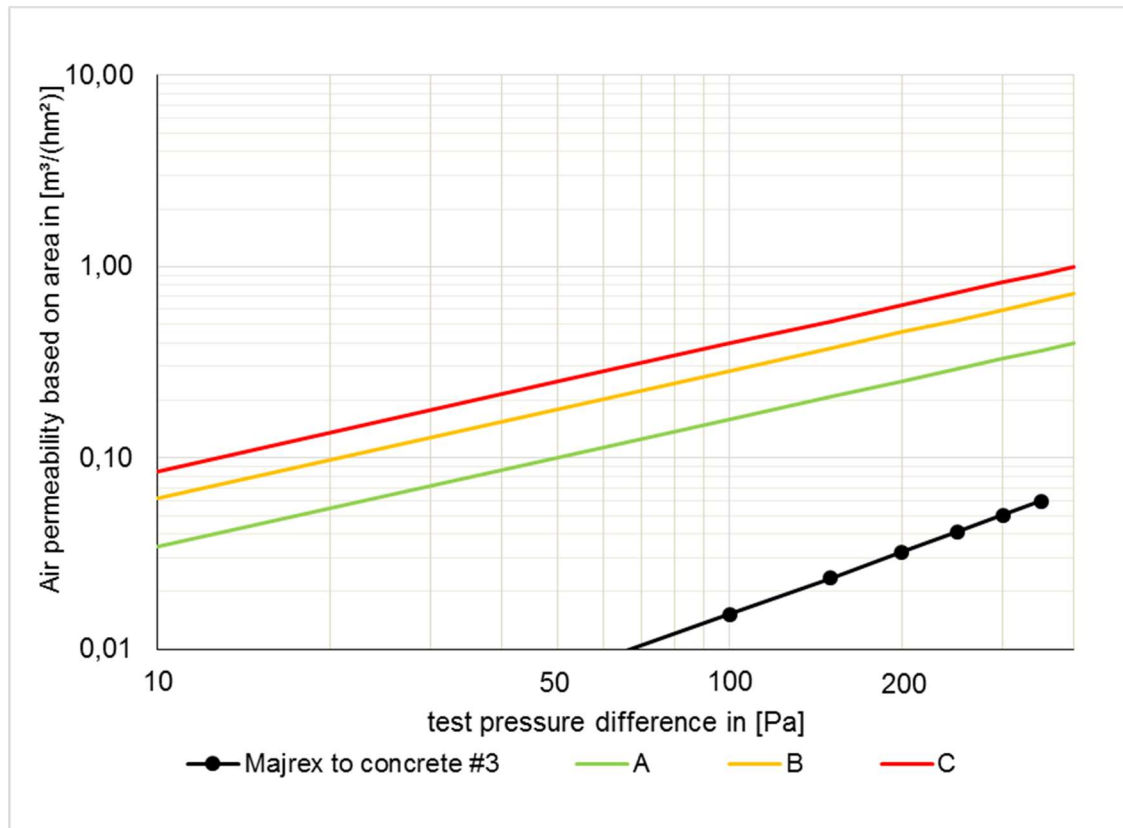

Fig. 17: Series of measurements for the sample "SIGA Majrex to concrete slab #3". The certificate classes A to C according to the PHI are entered in addition.

## 7. Test conditions

The indoor climate conditions during the measurements were as follows:

Indoor temperature: 19.1 – 22.4 °C

Indoor air humidity: 42 – 55 % r.H.

## 8. Measurement devices

A laminar flow element by the company TetraTec® Instruments was used for measuring the volume flow. The differential pressure was measured using an automated performance testing system (APT) by the manufacturer The Energy Conservatory.

Table 6: Overview of the used measurement devices

Name	Device type	Serial number	Measurement range	Measurement accuracy
LaminarMasterFlow-System	LMF	PH796	0-85 l/min	2% in the range of 8-80 l/min
<b>TEC Automated Performance Testing</b>	APT	0072 4	0-2000 Pa	1 %

## 9. Results

The results of these measurements were compiled and the overall average value was created according to the type of connection. In doing so, the measured value for the membrane on its own (without any joining) was not taken into account because this concerns certification as a system and not material testing only. On average, this resulted in an air permeability value of **0.02 (±0.002) m<sup>3</sup>/(hm<sup>2</sup>)** standardised for a test pressure of 50 Pa. The certification class "A" was achieved.

**Table 7: Overview of the results of the airtightness measurement.**

Average value of	m <sup>3</sup> /(hm <sup>2</sup> ) @ 50 Pa
Membrane to membrane	0.03
Membrane to OSB	0.01
Membrane to concrete	0.02
<b>Overall</b>	<b>0.02 (±0.002)</b>

**Table 8: Requirement class achieved by the examined product for certification as an "Airtightness system window connection" according to the specifications of the Passive House Institute**

Class	Air permeability per unit area @ 50 Pa [m <sup>3</sup> /(hm <sup>2</sup> )]	Class achieved
<b>phA</b>	<b>≤ 0.10</b>	<b>✓</b>
phB	≤ 0.18	
phC	≤ 0.25	

Darmstadt, 24.02.2017



Søren Peper

