

YKH2G-SHP Pro Version



		YKH2G-SHP-150	YKH2G-SHP-170	YKH2G-SHP-270
Q _{max}	[m³/h]	150	170	270
Q _{ref}	[m³/h]	105	120	190
P _{el}	[W]	56	23	47,8
η _{L_rvu}	[%]	87%	92,1%	84,4%
SPI	[W/m³/h]	0,227	0,193	0,24
CTRL	-	0,85	0,85	0,85
SEC	[kWh/m²a]	-39,90	-42,05	-38,9
Energy class	-	A	A+	A
Filter efficiency	-	ePM ₁ 55% - F7		
		ePM ₁₀ 50% - M5		
L _{WA}	[dBa]	38,0	44,9	41,3
LK _I	[%]	1,8%	0,5%	0,4%
LK _E	[%]	0,8%	2,3%	1,1%
HEP	[W]	-	600	900

LEGEND | all terms must be considered in compliance with Standard EU 1253/2014
 Q_{max}: Maximum flow rate, at max. motor speed and external static pressure of 100 Pa
 Q_{ref}: Reference flow rate - 70% di Q_{max}
 P_{el}: Power supply at Q_{ref} and external static pressure of 50 Pa
 η_{L_rvu}: Thermal efficiency at Q_{ref}
 SPI: Specific power input
 CTRL: Control factor - Centralised automatic control
 SEC: Specific energy consumption
 L_{WA}: Sound power level emitted by structure
 LK_I: Internal leakage at 100 Pa compared to Q_{ref}
 LK_E: External leakage at 250 Pa compared to Q_{ref}
 HEP: Pre-heater power (only mod. SHPEL and SHPER)

DIMENSIONS AND WEIGHT

YKH2G-SHP-150 Pro Version

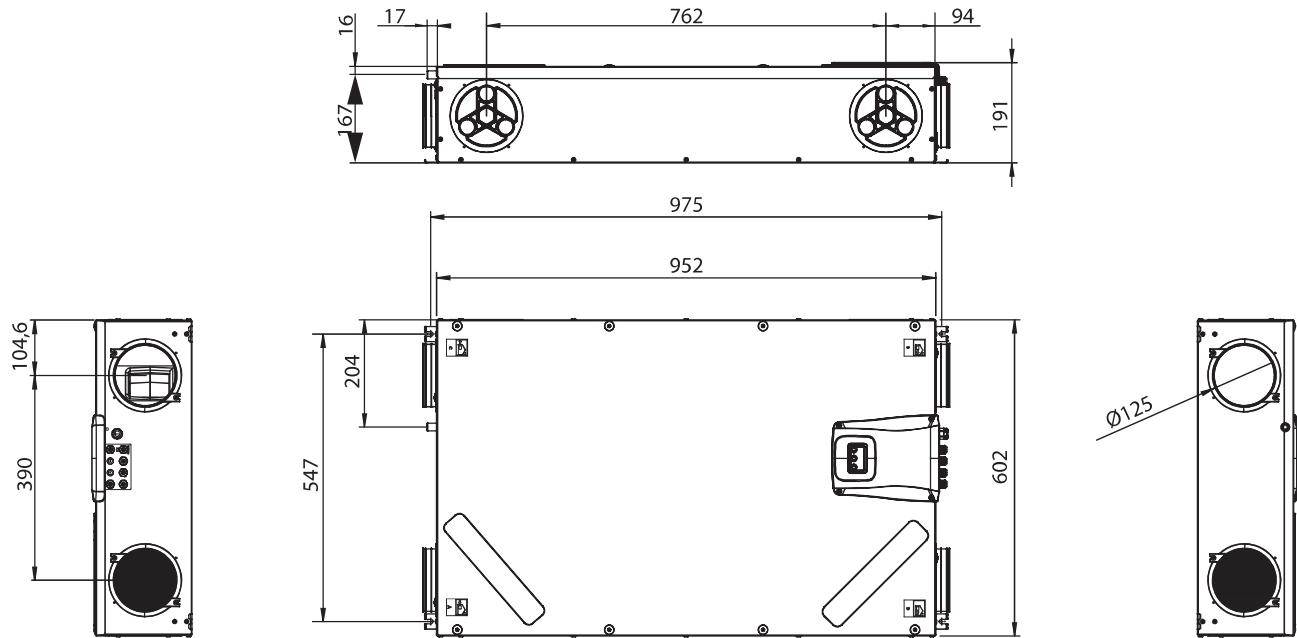

	Weight with packaging	Weight without packaging
YKH2G-SHP-150	25 kg	23 kg

Installation

The YKH2G-SHP-150 unit can easily be installed both horizontally and vertically.

Special support brackets pre-fitted on the unit are provided to install the unit horizontally on the ceiling and to install the unit vertically (especially in gaps between plasterboard walls and load-bearing walls).

The instruction manual indicates the appropriate maintenance clearance for each type of installation.

Horizontal installation

Spacer bars can be used to adjust the distance from the ceiling. It is recommended to install the unit tilted towards the side where the ePM₁ 55% - F7 filter is placed, in order to facilitate condensate drainage. Provide a slope of min. 5 mm towards the condensate drain.

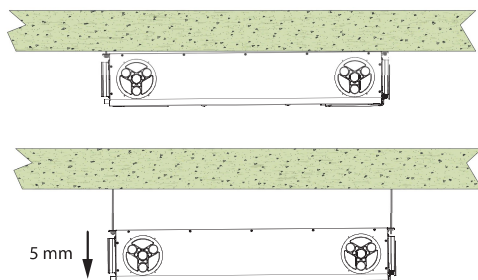

Vertical installation

Place the unit with the touch screen control upwards, so that the condensate drain connection remains downwards.

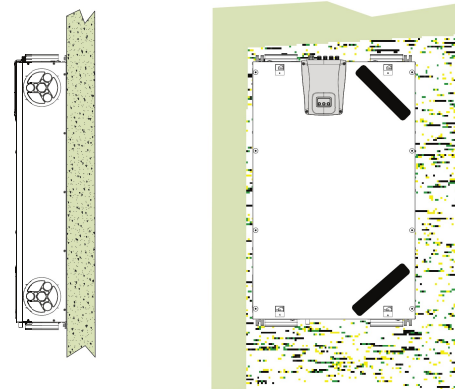

TECHNICAL DATA

Pro YKH2G-SHP-150 version with advanced air flow control

Model		YKH2G-SHP-150
Depth	mm	952
Width	mm	602
Height	mm	191
Duct connection	-	DN125
Weight ¹	kg	23
Maximum flow rate	m ³ /h	150
External static pressure at maximum flow rate	Pa	100
Reference flow rate	m ³ /h	105
External static pressure at reference flow rate	Pa	50
Minimum flow rate	m ³ /h	60
Maximum supply external static pressure	Pa	150
Thermal efficiency at reference flow rate EN 13141-7	%	87%
Filtering efficiency ISO 16890	-	ePM ₁ 55% - F7 supply / ePM ₁₀ 50% - M5 extraction
Fan type	-	Centrifugal fan with EC brushless motor and forward curved blades
Maximum power absorbed by controls and fans ³	W	59
Maximum current absorbed by controls and fans	A	0,5
Power supply	-	Single phase - 230 V – 50 Hz via 1.5 m cable with Schuko CEE 7/7 connection
Standby power		< 1W
Safety features		IP protection rating: IP21 CE compliance ²
Components and general materials	-	Recovery unit: counterflow plate heat recovery unit. Main power board with Modbus interface built-in display. Filters: micro-pleated type - synthetic. Main structure: polystyrene. Temperature sensors PT1000. External covering: painted galvanized steel plate. Humidity Sensor Central Demand Control for Extract Air. Condensate drain pipe L=800 mm.
Accessories	-	T-EP capacitive touch pad integrated control. External Electric Heater.
Maximum Defrost Pre-Heater power ⁴	W	600
Maximum electric heater current	A	3

¹ Without packaging

² EN 60335-1, EN 60335-2-80, EN 62233, EN 55014-1, EN 55014-2, EN 61000-3-2, EN 61000-3-3, EN 50581, Reg. 1253/14, Reg. 1254/14 (EU Directives: 2014/35/EU, 2014/30/EU, 2006/42/EU, 2011/65/EU)

³ Maximum power absorbed under ErP conditions with 100Pa maximum flow rate

⁴ External electric heater (Accessory)

EFFICIENCY CURVES

YKH2G-SHP-150

All mechanical efficiency curves are measured in standard air conditions (1 atm, 20 °C)

- Air flow: min. 60 m³/h, max. 150 m³/h.
- Curves with nominal flow rate 60, 83, 105, 128, 150 m³/h.

Supply air

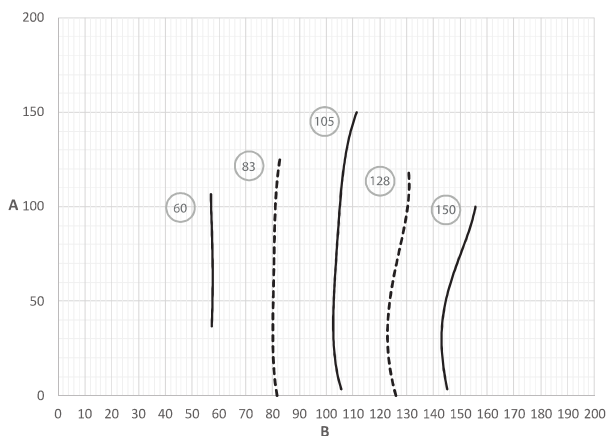

⊗ = Nominal flow rate
 A = Available static pressure [Pa]
 B = Perfectly balanced air flow [m³/h] at standard conditions

Extract air

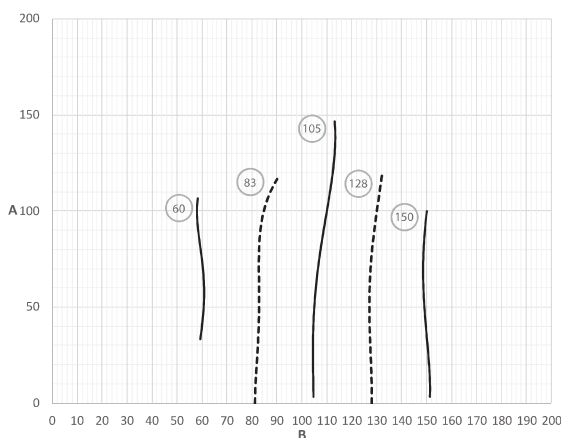

⊗ = Nominal flow rate
 A = Available static pressure [Pa]
 B = Perfectly balanced air flow [m³/h] at standard conditions

Electrical power input

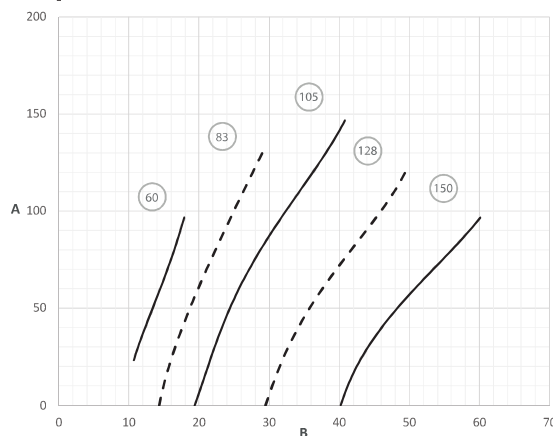

⊗ = Nominal flow rate
 A = Available static pressure [Pa]
 B = Power absorbed [W]

The curves apply in the event of balanced flow rates.

The minimum voltage indicated only refers to a minimum value that can be configured during the nominal flow rate calibration procedure.

In fact, during normal operation the motors can operate at lower voltages.

Table of compliance with Regulations EU 1254/14 Annex IV - YKH2G

Supplier name or brand	York								
	YKH2G-SHP-150			YKH2G-SHP-170			YKH2G-SHP-270		
Supplier model identification									
Specific energy consumption SEC in [kWh/(m ² a)] for each applicable climate zone (temperate, hot, cold, climate)	-39,90	-15,4	-78,0	-42,05	-16,8	-81,5	-38,90	-14,8	-76,4
SEC class - temperate climatic zone	A			A+			A		
Type declared according to EU 1253/14	BVU			BVU			BVU		
Type of drive installed	Continuous speed variator								
Type of heat recovery system	Static sensitive heat recovery unit								
Thermal efficiency	87,0%			92,1%			84,4%		
Max. flow rate [m ³ /h]	150			170			270		
Power absorbed by the fan drive, including all motor control devices, at maximum flow rate [W]	59			50			105		
Sound power level (LWA) in [dB(A)]	38,0			44,9			41,3		
Reference flow rate [m ³ /h]	105			120			190		
Reference pressure difference [Pa]	50			50			50		
SPI [W/(m ³ /h)]	0,227			0,193			0,240		
Control factor and type of control	0,85			0,85			0,85		
	Centralised ambient control with humidity sensor			Centralised ambient control with humidity sensor			Centralised ambient control with humidity sensor		
Maximum percentages declared [%] of internal and external leakage	Internal leakage: 1,8%			Internal leakage: 0,5%			Internal leakage: 0,4%		
	External leakage: 0,8%			External leakage: 2,3%			External leakage: 1,1%		
Position and description of the visual warning signal relating to the filter for RVUs intended for use with filters, including a text that emphasizes the importance of replacing the filter at regular intervals in order to safeguard unit performance and energy efficiency.	<p>Please refer to the following parts of the brochure:</p> <ul style="list-style-type: none"> - T-EP control description; - recommendations for filter replacement: filters clogging could result into relevant flow rate reduction, which implies the need of frequent windows opening and consequent thermal demand increase. Proper replacement period depends on background air quality, which can broadly vary between city centers and countryside. <p>In order to prevent filters clogging, optimum average period for filters replacement is 3 month. However, due to normal dust collection and spring pollens, maximum suggested period should not exceed 6 months.</p> <p>Filters replacement period can be modified by maintainer with a precision of days (min 30, max 360).</p>								
Internet address with the disassembly instructions	www.york.com								
AEC (Annual Energy Consumption) [kWh/a]	250	205	787	220	175	757	262	217	799
AHS - (Annual Heating Energy Savings) [kWh/a]	4548	2057	8898	4690	2120	9170	4478	2025	8760