



Report - Certified Passive House Component | Bericht - Zertifizierte Passivhaus Komponente

Passive House Institute

Recommended for | Empfohlen für
Warm, temperate climate | Clima cálido - templado



Passive House Institute
Rheinstraße 44/46
64283 Darmstadt
GERMANY

+49.6151.82699.0

mail@passiv.de
www.passiv.de

Product | Producto:

Client | Fabricante:

Spacer | Separador:

Date | Fecha:

Author | Autor:

Certification Kubus

GEALAN Fenster-Systeme GmbH

SWISSPACER Ultimate

14.07.2018

Dr.-Ing. Benjamin Krick

Window system
Sistema de ventana

1249wi04

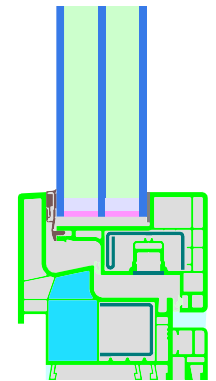

Because a separate heating system is not necessarily required in Passive Houses, high demands are placed on the quality of the building components used. The colder the climate, the higher the requirements for the components. To cover this, PHI has identified regions of similar requirements, and defined certification criteria. These criteria are available for free download at the website of the Passive House Institute.

If no radiator is placed under the window, its thermal transmittance U_w (U-value) may not exceed a climate-dependent value in order to prevent unpleasant radiation losses and cold down draughts. For a given quality of glazing, this results in restriction of the thermal losses of the window frame and the glass edge. In that context, the installation situation of the window in the wall is relevant. Because of that, a $U_{w,installed}$ exemplary tested for the certification has been defined.

Also the hygiene criterion must be met. For reasons of hygiene, this criterion limits the minimum individual temperature on window surfaces to prevent condensate and mold growth.

The below stated requirements for awarding the label "Certified Passive House Component" have been set by the Passive House Institute (PHI).

Passivhäuser stellen aufgrund der Möglichkeit, auf ein separates Heizsystem zu verzichten, hohe Anforderungen an die Qualität der verwendeten Bauteile. Dabei steigen die Anforderungen, je kälter das Klima ist. Darum hat das Passivhaus Institut Regionen gleicher Anforderung identifiziert und für diese Zertifizierungskriterien festgelegt. Die Kriterien sind auf der Homepage des Passivhaus Instituts als kostenfreier Download verfügbar.

verwendeten Fenster (Fenster-U-Wert) U_w einen vom Klima abhängigen Höchstwert nicht überschreiten, damit es nicht zu störendem Strahlungswärmeentzug und Kaltluftabfall am Fenster kommt. Daraus ergeben sich bei gegebener Verglasungsqualität Grenzen für den Wärmeverlust im Bereich des Fensterrahmens. In diesem Kontext ist die Einbausituation des Fensters relevant. Darum wurde auch für $U_{w,eingebaut}$ ein Maximalwert festgelegt, der im Rahmen der Zertifizierung beispielhaft geprüft wurde.

Des Weiteren ist das Hygienekriterium zu erfüllen. Dieses Kriterium begrenzt die minimale Einzeltemperatur an der Innenseite der Fensteroberfläche, um Tauwasserausfall und Schimmelbildung zu vermeiden.

Durch das Passivhaus Institut (PHI) wurden die unten stehenden Anforderungen zum Erlangen der Auszeichnung "Zertifizierte Passivhaus Komponente" festgesetzt.

Wird keine gezielte Heizwärmezufuhr unter den Fenstern vorgesehen, darf der Wärmedurchgangskoeffizient der

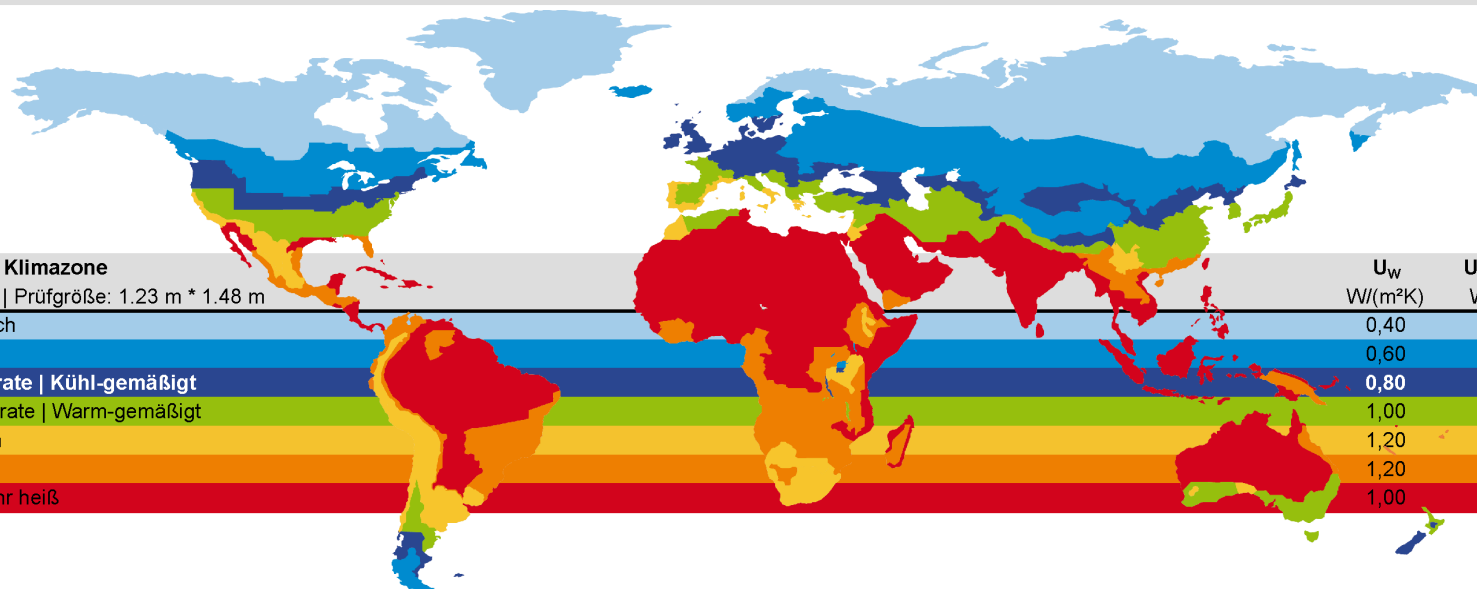

Certified windows are ranked by the thermal losses through the not transparent parts. These **efficiency classes** include the U-Value of the frame, the frame width, the Ψ -Value of the Glass edge and the length of the Glass edge.

Relevant for passive houses is the energy balance, the sum out of losses and gains. Because the solar gains are difficult to quote it is useful to rate the parts of the window, which do not allow solar gains. This is determined by Ψ_{opaque} .

Die Fenster werden abhängig von den Wärmeverlusten durch den opaken Teil in **Effizienzklassen** eingestuft. In diese Wärmeverluste gehen die Rahmen-U-Werte, die Rahmenbreiten, die Glasrand- Ψ -Werte und die Glasrandlängen ein. Für das Passivhaus ist die Bilanz aus Wärmeverlusten und Wärmegewinnen relevant. Da die solaren Gewinne schwer fassbar sind, ist es zweckmäßig, die Verluste über die Bereiche zu quantifizieren und zu einer Bilanzierung heran zu ziehen, über die keine solaren Gewinne möglich sind. Dies leistet Ψ_{opak} .

$$\Psi_{opak} = \Psi_g + \frac{U_f \cdot A_f}{l_g}$$

max. Ψ_{opak} [W/(mK)]	Efficiency class Effizienzklasse	Name Bezeichnung
0,065	phA+	Very advanced component
0,110	phA	Advanced component
0,155	phB	Basic component
0,200	phC	Certifiable component

The simulation of the thermal values of the frame sections are based on the regulations of the standard ISO 10077-1:2010 and 10077-2:2012. The thermal conductivities of the used materials refer to relevant standards, technical approvals or have been determined by measured values according to ISO 10077-2:2012, chapter 5.1. In case of one glazing, the models are to 40 cm height, in case of 2 glazing 60 cm in height.

The **spacers** were modeled according to the actual 2-Box-models of the working group "Warm Edge" of

Die **Berechnung der thermischen Kennwerte** der Rahmenschnitte erfolgte auf der Grundlage der ISO 10077-1:2010 und 10077-2:2012. Die Wärmeleitfähigkeiten stammen aus einschlägigen Normen, bauaufstichtlichen Zulassungen oder wurden anhand von messwerten nach den Regeln der ISO 10077-2:2012 Abschnitt 5.1 determiniert. Dabei sind die Modelle mit einem Glasteil stets 40 cm, Modelle mit 2 Glasteilen stets 60 cm hoch.

Zur Abbildung der **Abstandhalter** wurde auf die jeweils aktuellen 2-Box-Modelle des Arbeitskreises Warme Kante des Bundesverbandes Flachglas zurückgegriffen.

the Federal glass association (Bundesverband Flachglas) of Germany. Thermal bridge coefficients were calculated for typical **installation situations**. These values may be used in case of identical installations only in energy balance calculations. The wall-models are 1.41 m in height, glass and frame are 40 cm height, the installation gap is 1 cm.

For modeling and simulations, the software Flixo 7 of Infomind was used. For the used **boundary conditions**, please have a look at following drawings and tables.

Die **Wärmebrückenverlustkoeffizienten** wurden beispielhaft für typische **Wandaufbauten** berechnet. Diese dürfen in der Gebäudeenergiebilanzierung nur bei identischer Konstruktion zum Ansatz gebracht werden. Die Modelle für Wandaufbauten sind stets 1,41 m hoch, wobei die Höhe des Glases und Rahmens 40 cm beträgt. Es wird eine Einbaufuge von 1 cm angesetzt.

Zur Berechnung der Bildung der Modelle und zur Berechnung der Wärmeströme wurde das Programm Flixo 7 Professional der Firma Infomind genutzt. Die Randbedingungen wurden wie unten gezeigt angesetzt.

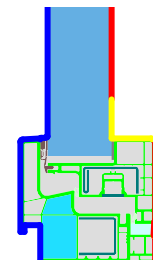

Randbedingung	q [W/m ²]	θ [°C]	R [(m ² ·K)/W]	ϵ
Adiabatic Adiatat	0,000			
Exterior Außen		-10,000	0,040	
Interior, frame, normal		20,000	0,130	
Interior, frame, reduced		20,000	0,200	
e 0,3 Cavity in metal				0,300
e 0,9 Cavity Hohlräum				0,900

Randbedingung	q [W/m ²]	θ [°C]	R [(m ² ·K)/W]	ϵ
Adiabatic Adiatat	0,000			
Exterior Außen		-10,000	0,040	
e 0,3 Cavity in metal				0,300
e 0,9 Cavity Hohlräum				0,900
fRsi: Interior Innen		20,000	0,250	

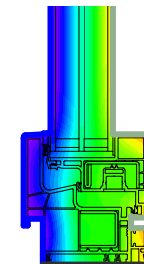

GEALAN Fenster-Systeme GmbH		bo	to	si	bof	tof	sif	th	sh	fm Flying	m2	m1	m	ec	t2	t1	t
		Bottom	Top	Side	Bottom fixed	Top fixed	Side fixed	Thres- hold	Side door	mullion	Mullion	Mullion	Mullion fixed	Corner	Transom	Transom	Transom fixed
Certification Kubus		Inferior	Superior	Lateral	Inferior fijo	Superior fijo	Lateral fijo	Umbral	Puerta lateral	Montante móvil	Montante	Montante	Montante fijo	Esquina	Trave- saño	Trave- saño	Trave- saño fijo
Spacer Separador: SWISSPACER Ultimate																	
Temperaturefactor Factor de temp.	$f_{Rsi}=0,25m^2k/W$	0,69	0,70	0,70	0,69	0,70	0,70	0,56		0,66	0,65	0,66	0,66		0,65	0,66	0,66
Frame width Ancho del marco	b_f [mm]	100	100	100	100	100	100	74		100	154	100	100		154	100	100
U-value frame Valor-U marco	U_f [W/(m²K)]	1,05	0,98	0,98	1,05	0,98	0,98	2,50		1,36	1,42	1,36	1,36		1,42	1,36	1,36
Ψ-glass edge Ψ borde del vidrio	Ψ_g [W/(mK)]	0,022	0,023	0,023	0,022	0,023	0,023	0,024		0,023	0,023	0,023	0,023		0,023	0,023	0,023
U-value window Valor-U ventana	U_w [W/(m²K)] @ $U_g=0,9$ W/(m²K)	0,984			0,984					Contact person Ansprechpartner GEALAN Fenster-Systeme GmbH, Ute Richter +499286774105 ute.richter@gealan.de							
Ψ _{opaque}	Ψ_{opaque} W/(mK)	0,131			0,131					Construction: PVC frame with PU foam (IKD®, 0.026 W/(mK)) insulated chamber. The required temperature factor is not achieved at the threshold. The airtightness was approved for a window-door with fixed part (3305 * 2546 mm). Frame 5060 with reinforcement 8727, sash 5061 reinforcement 5760, mullion 5062 with reinforcement 5762 and 5260 with reinforcement 5763, mullion 5063 with reinforcement 5767, threshold 2596/2576 with 5463 and 6105. Pane thickness: 48 mm (4/18/4/18/4), rebate depth: 13 mm.							
Passive House efficiency class Clasificación de eficiencia Passive House		phB			phB												
EIFS SATE U-Wall = 0,228 W/(m²K)																	
	$\Psi_{install}$ [W/(mK)]	0,050	0,000	0,000	0,050	0,000	0,000	0,072									
	$U_{w, installed}$ [W/(m²K)]	1,02			1,02												
Lightweight timber construction Entramado ligero de madera U-Wall = 0,189 W/(m²K)																	
	$\Psi_{install}$ [W/(mK)]	0,020	0,007	0,007	0,020	0,007	0,007										
	$U_{w, installed}$ [W/(m²K)]	1,01			1,01												
Monolithic wall Muro monolítico U-Wall = 0,234 W/(m²K)																	
	$\Psi_{install}$ [W/(mK)]	0,009	-0,005	-0,005	0,009	-0,005	-0,005										
	$U_{w, installed}$ [W/(m²K)]	0,98			0,98												
Ventillated facade Fachada ventilada U-Wall = 0,133 W/(m²K)																	
	$\Psi_{install}$ [W/(mK)]																
	$U_{w, installed}$ [W/(m²K)]																
Cavity wall Muro con cámara U-Wall = 0,130 W/(m²K)																	
	$\Psi_{install}$ [W/(mK)]																
	$U_{w, installed}$ [W/(m²K)]																
										Calculation Cálculo Passivhaus Institut Darmstadt 14.07.2018							



frame values Rahmenwerte		GEALAN Fenster-Systeme GmbH						Classification according to EN 14351-1, carried out by ift Rosenheim											
		V1 bo Bottom	V1 to Top	V1 s Side	V1 bof Bottom fixed	V1 tof Top fixed	V1 sf Side fixed	Clasificación según EN 14351-1, realizada por ift Rosenheim											
		Inferior	Superior	Lateral	Inferior fijo	Superior fijo	Lateral fijo	Window-type Tipo de ventana	Reference number Número de referencia	Resistance to wind Resistencia al EN 12210	Water tightness Estanqueidad al agua EN 12208	Air tightness Luftdichtheit EN 1220 Q100							
Certification Kubus																			
Spacer Separador: SWISSPACER Ultimate																			
Temperaturefactor Factor de temp.	$f_{Rsi}=0,25m^2k/W$																		
Frame width Ancho del marco	b_f [mm]						1572 * 2376 mm												
U-value frame Valor-U marco	U_f [W/(m²K)]																		
Ψ-glass edge Ψ borde del vidrio	Ψ_g [W/(mK)]						3290 * 2372 mm												
U-value window Valor-U ventana	U_w [W/(m²K)] @ $U_g=0,9$ W/(m²K)							16-0022300-PR03 PB-A01-0203-de-01	C5 / B4	8A	4								
Ψ _{opaque}	Ψ_{opaque} W/(mK)						2244 * 1700 mm											0,31 m³/hm	
Passive House efficiency class Clasificación de eficiencia Passive House																			
EIFS SATE U-Wall = 0,228 W/(m²K)																			
	$\Psi_{install}$ [W/(mK)]						1642 * 2372 mm												
	$U_{w, installed}$ [W/(m²K)]																		
Lightweight timber construction Entramado ligero de madera U-Wall = 0,189 W/(m²K)								16-0022300-PR02 PB-A01-0203-de-01	C4 / B4	9A	4								0,20 m³/hm
	$\Psi_{install}$ [W/(mK)]						3305 * 2546 mm												
	$U_{w, installed}$ [W/(m²K)]																		
Monolithic wall Muro monolítico U-Wall = 0,234 W/(m²K)																			
	$\Psi_{install}$ [W/(mK)]																		
	$U_{w, installed}$ [W/(m²K)]																		
Ventilated facade Fachada ventilada U-Wall = 0,133 W/(m²K)																			
	$\Psi_{install}$ [W/(mK)]																		
	$U_{w, installed}$ [W/(m²K)]																		
Cavity wall Muro con cámara U-Wall = 0,130 W/(m²K)																			
	$\Psi_{install}$ [W/(mK)]																		
	$U_{w, installed}$ [W/(m²K)]																		
									Criterion achieved		Criterion not achieved								



Material

Material	λ [W/(m·K)]	ϵ
Ar18 in 48 mm U 0,9	0,039	
EPDM	0,250	0,900
Glass Glas	1,000	0,900
PU foam 0,021*1.25	0,026	
Polysulfide Polysulfid	0,400	0,900
Polyvinylchloride (PVC)	0,170	0,900
STV-Klebeband	0,083	0,900
SWISSP. Ultimate Box 2 [cert]	0,140	
Soft PVC Weich-PVC	0,140	0,900
Steel Stahl	50,000	0,300
Steel Stahl	50,000	0,900
Unvent. cavity unbel. Hohlr. **		
slightly vent. cav. leicht bel. Hohlr. **		
** EN ISO 10077-2:2017, 6.4.3		

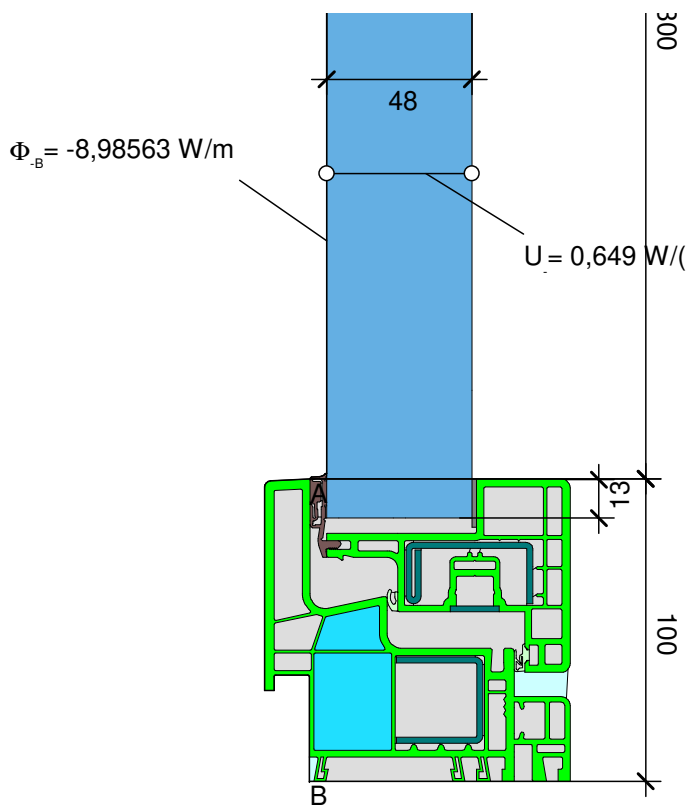

$$U_{fAB} = \frac{\Phi}{\Delta T} - \frac{U_p \cdot b_p}{b_f} = \frac{8,986}{30,000} - \frac{0,649 \cdot 0,300}{0,100} = 1,049 \text{ W/(m}^2 \cdot \text{K)}$$

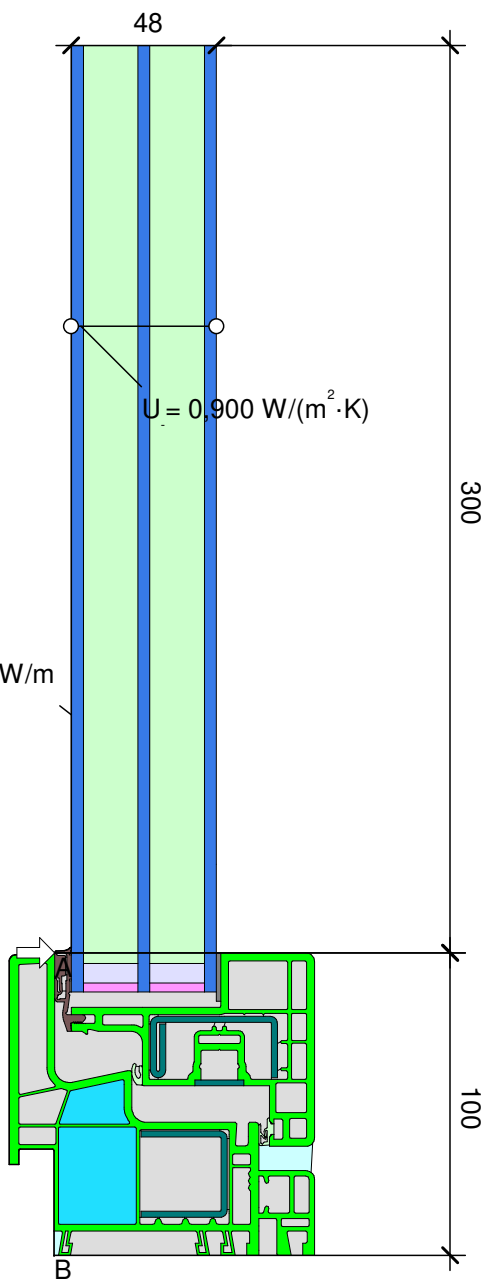

$$\psi_A = \frac{\Phi}{\Delta T} - U_g \cdot b_g - U_f \cdot b_f = \frac{11,918}{30,000} - 0,900 \cdot 0,300 - 1,049 \cdot 0,100 = 0,022 \text{ W/(m}^2 \cdot \text{K)}$$

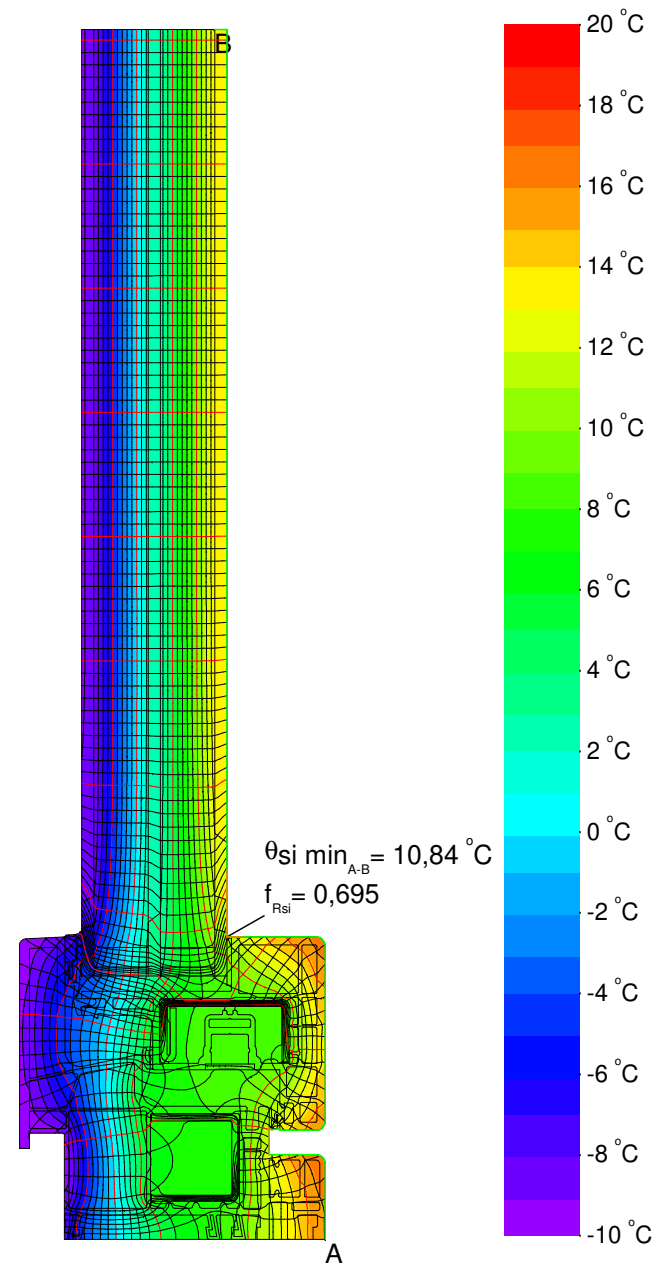

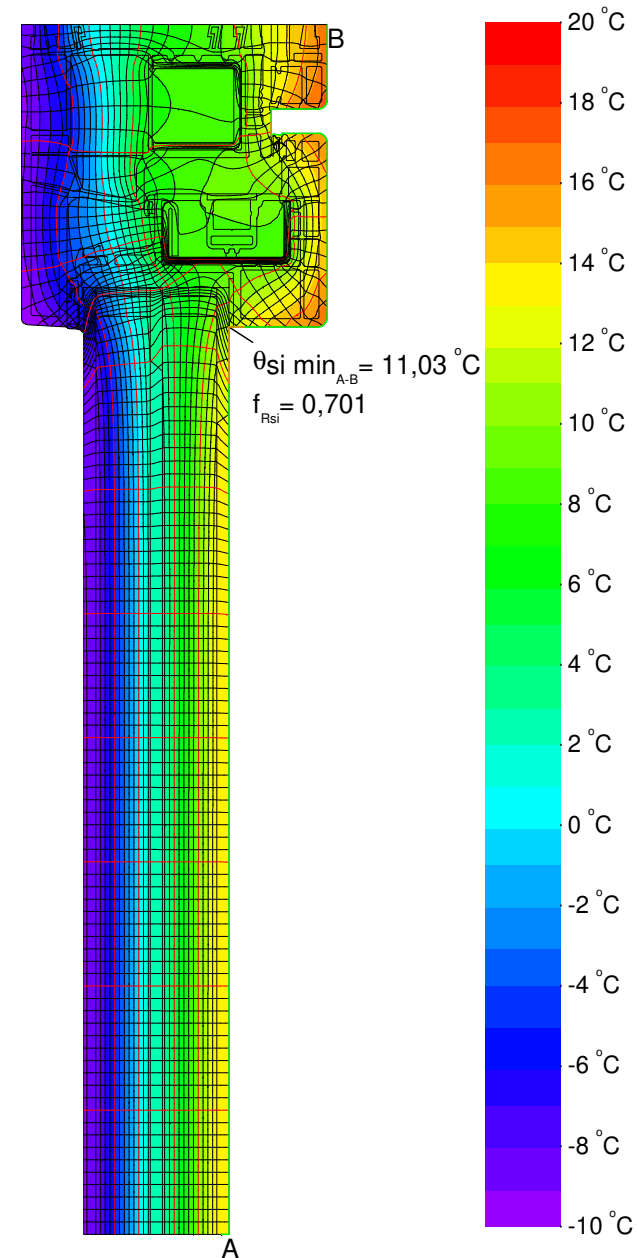
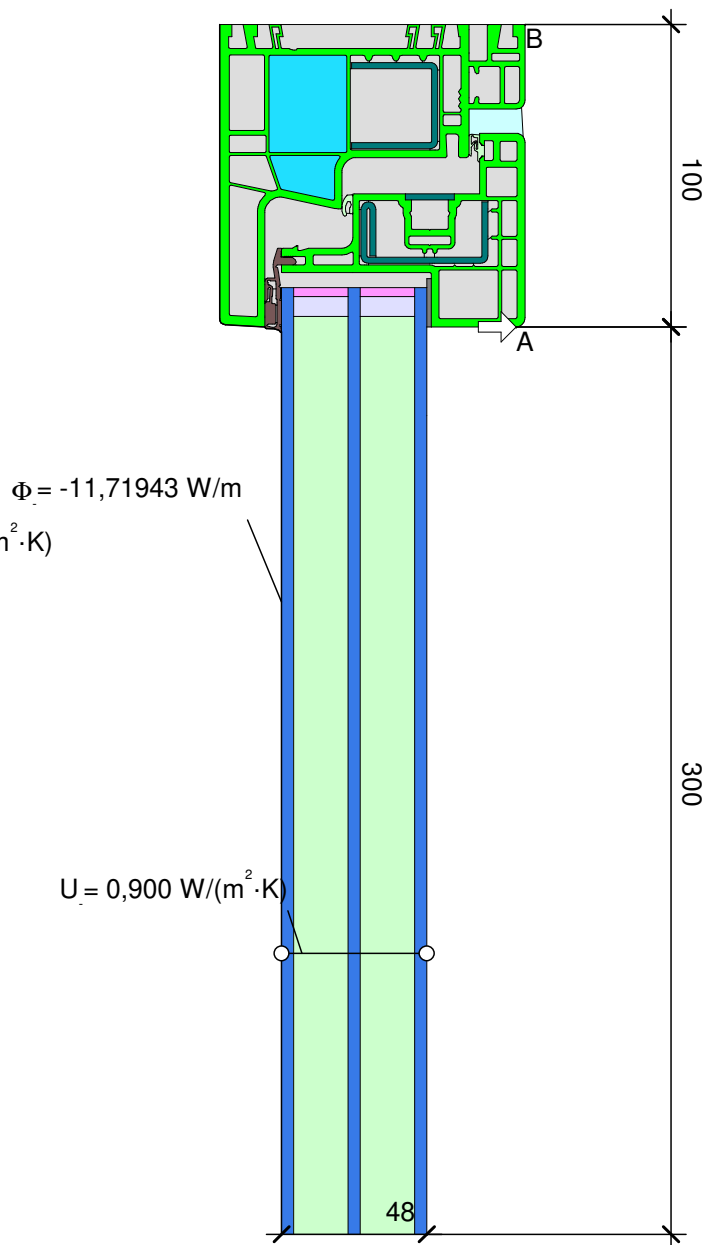
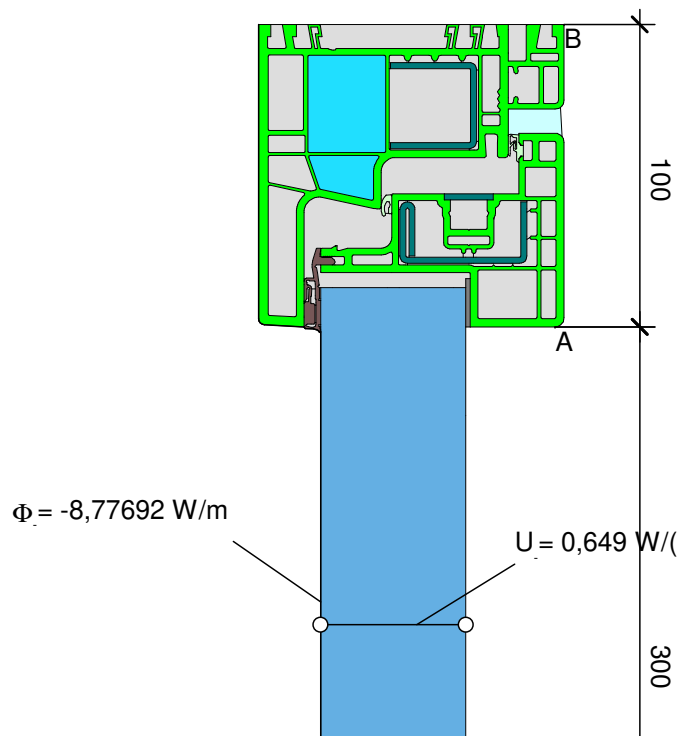

Material	λ [W/(m·K)]	ϵ
Ar18 in 48 mm U 0,9	0,039	
EPDM	0,250	0,900
Glass Glas	1,000	0,900
PU foam 0,021*1.25 (2)	0,026	
Polysulfide Polysulfid	0,400	0,900
Polyvinylchloride (PVC)	0,170	0,900
STV-Klebeband	0,083	0,900
SWISSP. Ultimate Box 2 [cert]	0,140	
Soft PVC Weich-PVC	0,140	0,900
Steel Stahl	50,000	0,900
Steel Stahl	50,000	0,300
Unvent. cavity unbel. Hohlr. **		
slightly vent. cav. leicht bel. Hohlr. **		

** EN ISO 10077-2:2017, 6.4.3

$$U_{i,A,B} = \frac{\frac{\Phi}{\Delta T} - U_p \cdot b_p}{b_f} = \frac{\frac{8,777}{30,000} - 0,649 \cdot 0,300}{0,100} = 0,979 \text{ W/(m}^2 \cdot \text{K)}$$

$$\psi_A = \frac{\Phi}{\Delta T} - U_g \cdot b_g - U_f \cdot b_f = \frac{11,719}{30,000} - 0,900 \cdot 0,300 - 0,979 \cdot 0,100 = 0,023 \text{ W/(m} \cdot \text{K)}$$



Material	λ [W/(m·K)]	ϵ
Aluminum Aluminium 10456	160,000	0,900
Ar18 in 48 mm U 0,9	0,039	
Bürstendichtung (polyesterbeschichtetes Mohair)	0,140	0,900
EPDM	0,250	0,900
Glass Glas	1,000	0,900
Polysulfide Polysulfid	0,400	0,900
Polyvinylchloride (PVC)	0,170	0,900
STV-Klebeband	0,083	0,900
SWISSP. Ultimate Box 2 [cert]	0,140	
Soft PVC Weich-PVC	0,140	0,900
Steel Stahl	50,000	0,900
Unbelüftete Hohlräume **		
Unvent. cavity unbel. Hohlr. **		
slightly vent. cav. leicht bel. Hohlr. **		
** EN ISO 10077-2:2017, 6.4.3		

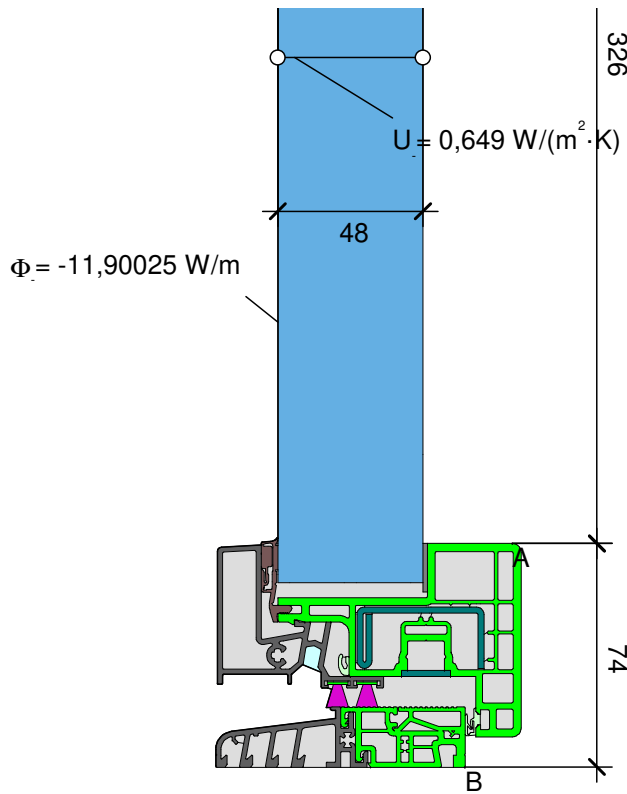

$$U_{fA,B} = \frac{\frac{\Phi}{\Delta T} - U_p \cdot b_p}{b_f} = \frac{\frac{11,900}{30,000} - 0,649 \cdot 0,326}{0,074} = 2,506 \text{ W/(m}^2 \cdot \text{K)}$$

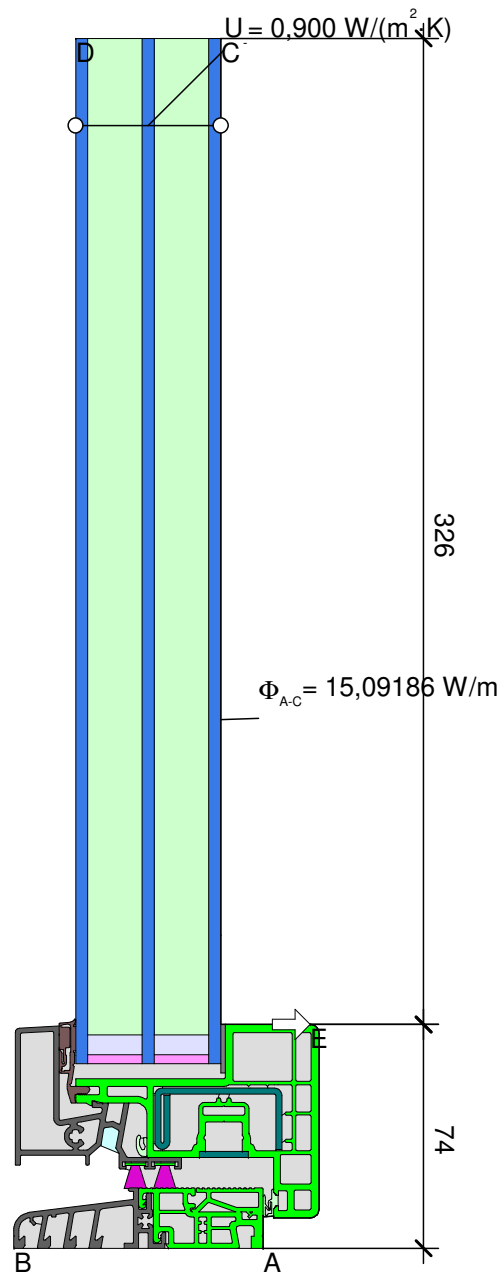

$$\psi_{A-E-C,*} = \frac{\Phi}{\Delta T} - U_1 \cdot b_1 - U_2 \cdot b_2 = \frac{15,092}{30,000} - 2,506 \cdot 0,074 - 0,900 \cdot 0,326 = 0,024 \text{ W/(m} \cdot \text{K)}$$

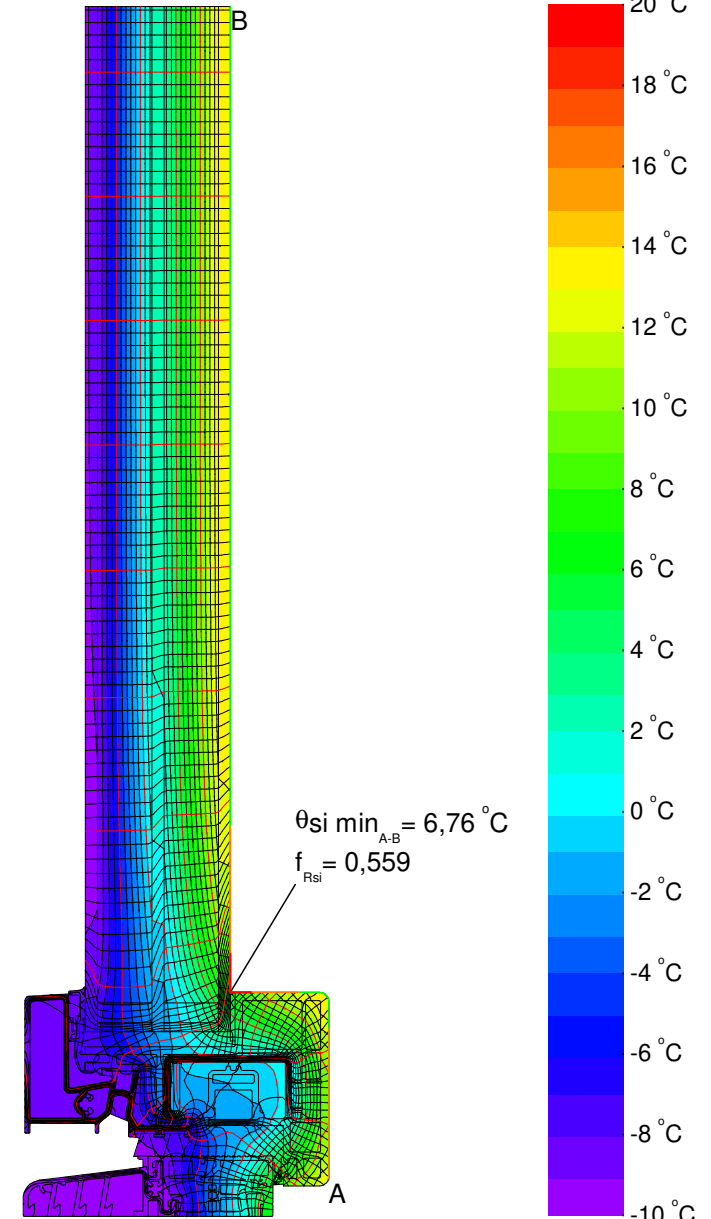

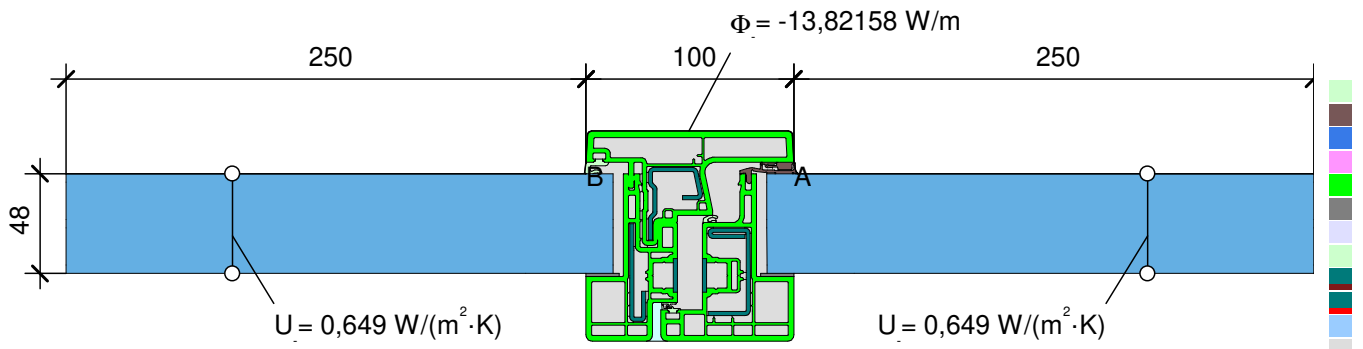

Material

Ar18 in 48 mm U 0,9	0,039	
EPDM	0,250	0,900
Glass Glas	1,000	0,900
Polysulfide Polysulfid	0,400	0,900
Polyvinylchloride (PVC)	0,170	0,900
STV-Klebeband	0,083	0,900
SWISSP. Ultimate Box 2 [cert]	0,140	
Soft PVC Weich-PVC	0,140	0,900
Steel Stahl	50,000	0,900
Steel Stahl	50,000	0,300
Unbelüftete Hohlräume **		
Unvent. cavity unbel. Hohlr. **		
slightly vent. cav. leicht bel. Hohlr. **		

** EN ISO 10077-2:2017, 6.4.3

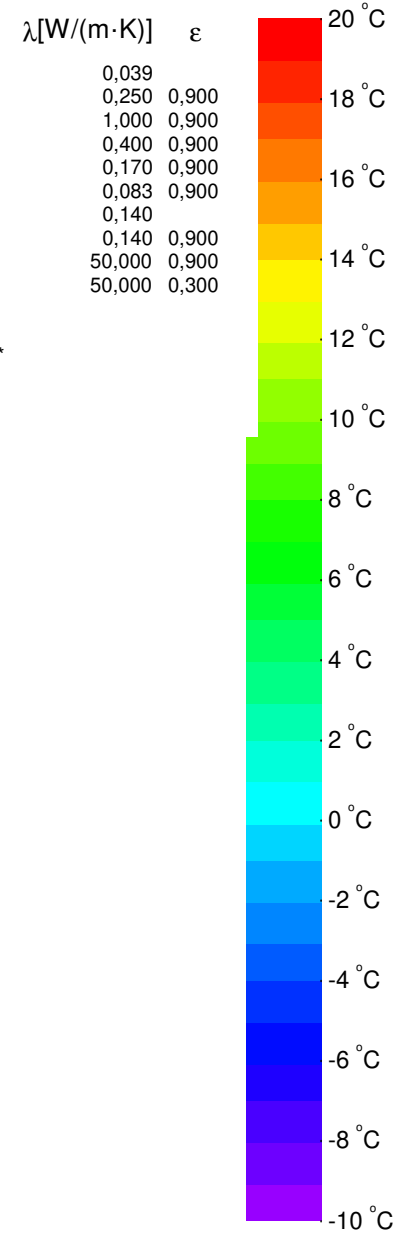

$$U_{fA,B} = \frac{\frac{\Phi}{\Delta T} - U_{p1} \cdot b_{p1} - U_{p2} \cdot b_{p2}}{b_f} = \frac{\frac{13,822}{30,000} - 0,649 \cdot 0,250 - 0,649 \cdot 0,250}{0,100} = 1,363 \text{ W/(m}^2 \cdot \text{K)}$$

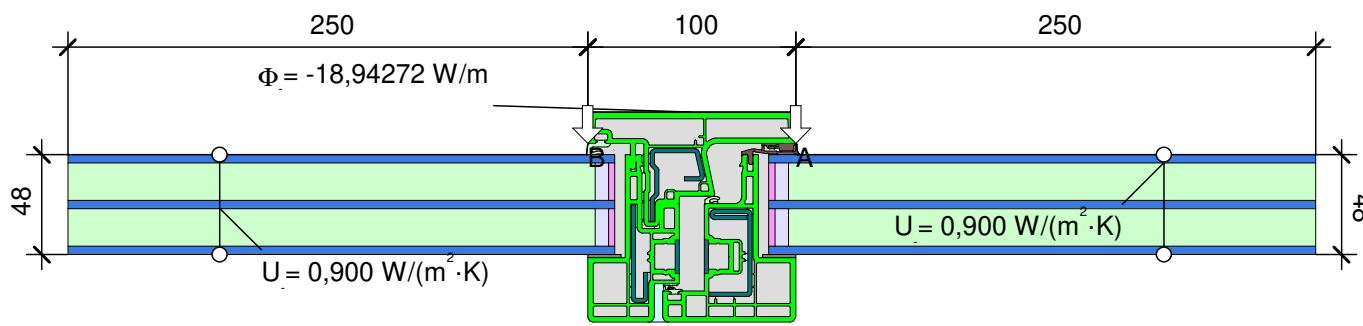

$$\Psi_{A,B} = \frac{\frac{\Phi}{\Delta T} - U_{g1} \cdot b_{g1} - U_f \cdot b_f - U_{g2} \cdot b_{g2}}{2} = \frac{\frac{18,943}{30,000} - 0,900 \cdot 0,250 - 1,363 \cdot 0,100 - 0,900 \cdot 0,250}{2} = 0,023 \text{ W/(m} \cdot \text{K)}$$

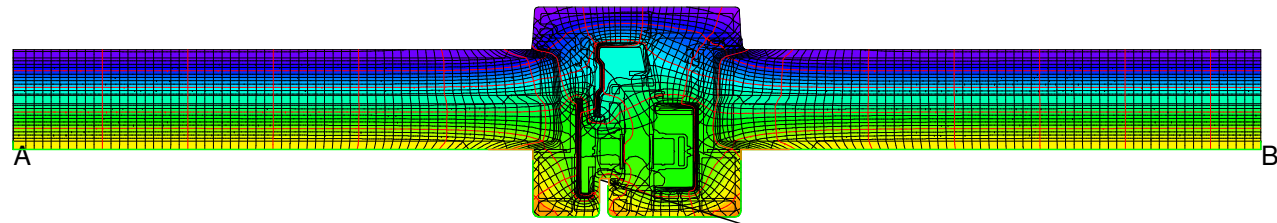

$\theta_{si \min}_{A-B} = 9,81 \text{ }^\circ\text{C}$
 $f_{Rsi} = 0,660$

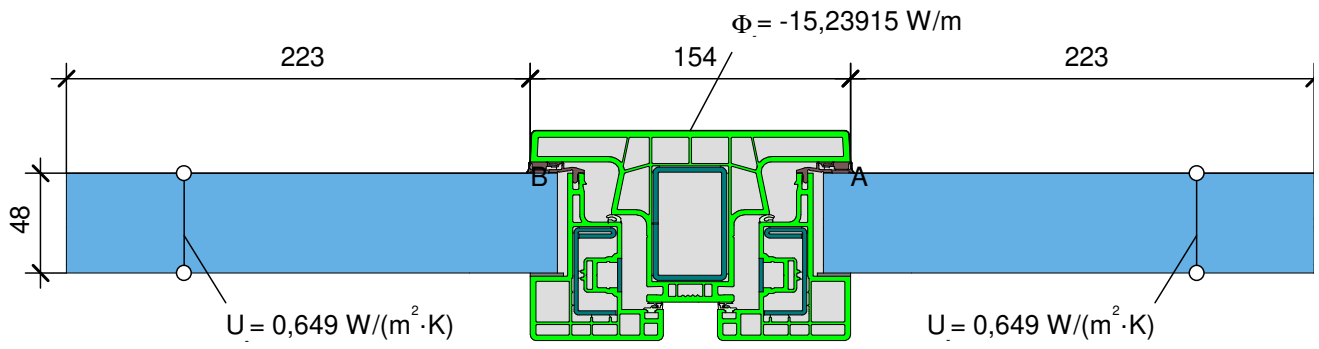

Material

Ar18 in 48 mm U 0,9	0,039	
EPDM	0,250	0,900
Glass Glas	1,000	0,900
Hart-Polyvinylchlorid (PVC)	0,170	0,900
Polysulfide Polysulfid	0,400	0,900
Polyvinylchloride (PVC)	0,170	0,900
STV-Klebeband	0,083	0,900
SWISSP. Ultimate Box 2 [cert]	0,140	
Soft PVC Weich-PVC	0,140	0,900
Steel Stahl	50,000	0,900
Unvent. cavity unbel. Hohlr.	**	**

** EN ISO 10077-2:2017, 6.4.3

λ [W/(m·K)]	ϵ
0,039	
0,250	0,900
1,000	0,900
0,170	0,900
0,400	0,900
0,170	0,900
0,083	0,900
0,140	
0,140	0,900
50,000	0,900

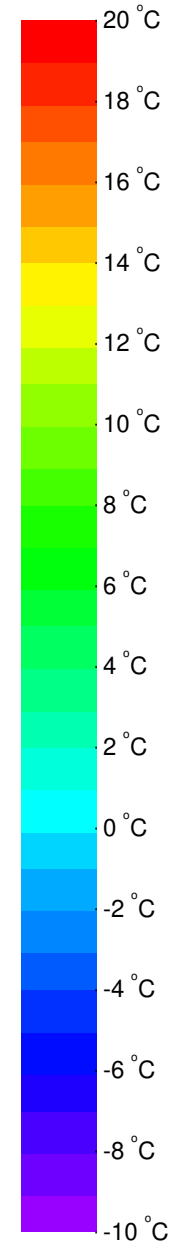

$$U_{f,A,B} = \frac{\frac{\Phi}{\Delta T} - U_{p1} \cdot b_{p1} - U_{p2} \cdot b_{p2}}{b_f} = \frac{\frac{15,239}{30,000} - 0,649 \cdot 0,223 - 0,649 \cdot 0,223}{0,154} = 1,420 \text{ W/(m}^2 \cdot \text{K)}$$

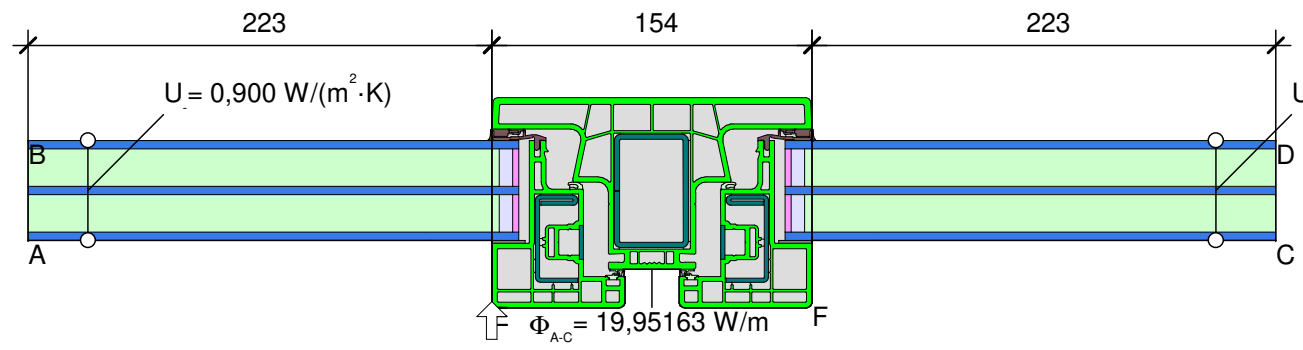

$$\psi_{A-E,C,\dots} = \frac{\Phi}{\Delta T} - U_1 \cdot b_1 - U_2 \cdot b_2 - U_3 \cdot b_3 = \frac{19,952}{30,000} - 0,900 \cdot 0,223 - 1,420 \cdot 0,154 - 0,900 \cdot 0,223 = 0,045 \text{ W/(m} \cdot \text{K)}$$

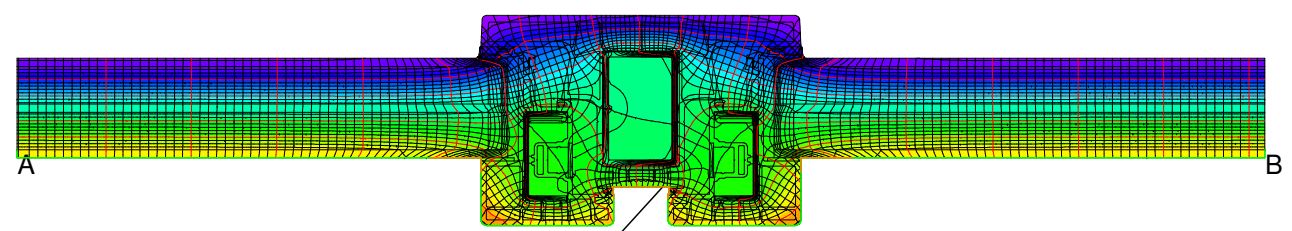

$\theta_{si \text{ min}}_{A-B} = 9,58 \text{ }^\circ\text{C}$
 $f_{Rsi} = 0,653$



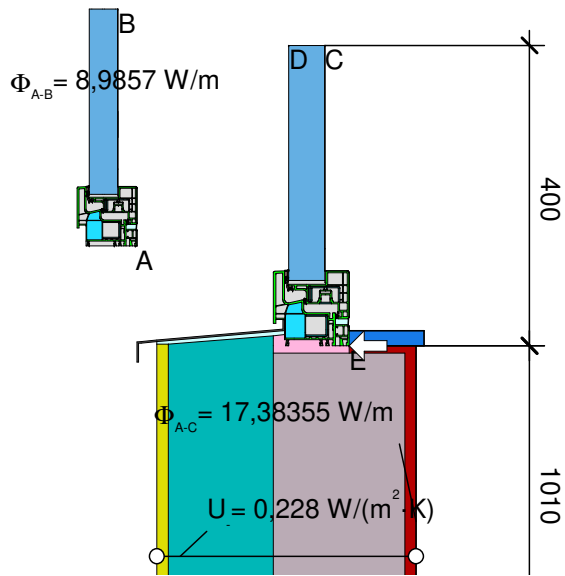

Material	λ [W/(m·K)]	ϵ
Aluminum Aluminium 10456	160,000	0,900
Artificial stone Kunststein 10456	1,300	
EPDM	0,250	0,900
Insulation Wärmedämmung 035	0,035	0,900
Interior plaster Gipsputz 10456	0,570	
Lime-cement plaster Kalkzementputz ISO 10456	1,000	0,900
PU foam 0,021*1.25 (5)	0,026	
PU in-situ foam PU-Ortschaum 040	0,040	0,900
Panel Maske	0,035	0,900
Polyvinylchloride (PVC)	0,170	0,900
STV-Klebeband	0,083	0,900
Sand-lime stone Kalksandstein 1745	1,000	
Soft PVC Weich-PVC	0,140	0,900
Steel Stahl	50,000	0,900
Steel Stahl	50,000	0,300
Unvent. cavity unbel. Hohlr. **		
slightly vent. cav. leicht bel. Hohlr. **		

- Aluminum | Aluminium 10456
 - Artificial stone | Kunststein 10456
 - EPDM
 - Insulation | Wärmedämmung 035
 - Interior plaster | Gipsputz 10456
 - Lime-cement plaster | Kalkzementputz ISO 10456
 - PU foam 0,021*1.25 (5)
 - PU in-situ foam | PU-Ortschaum 040
 - Panel | Maske
 - Polyvinylchloride (PVC)
 - STV-Klebeband
 - Sand-lime stone | Kalksandstein 1745
 - Soft PVC | Weich-PVC
 - Steel | Stahl
 - Steel | Stahl
 - Unvent. cavity | unbel. Hohlr. **
 - slightly vent. cav. | leicht bel. Hohlr. **
- ** EN ISO 10077-2:2017, 6.4.3

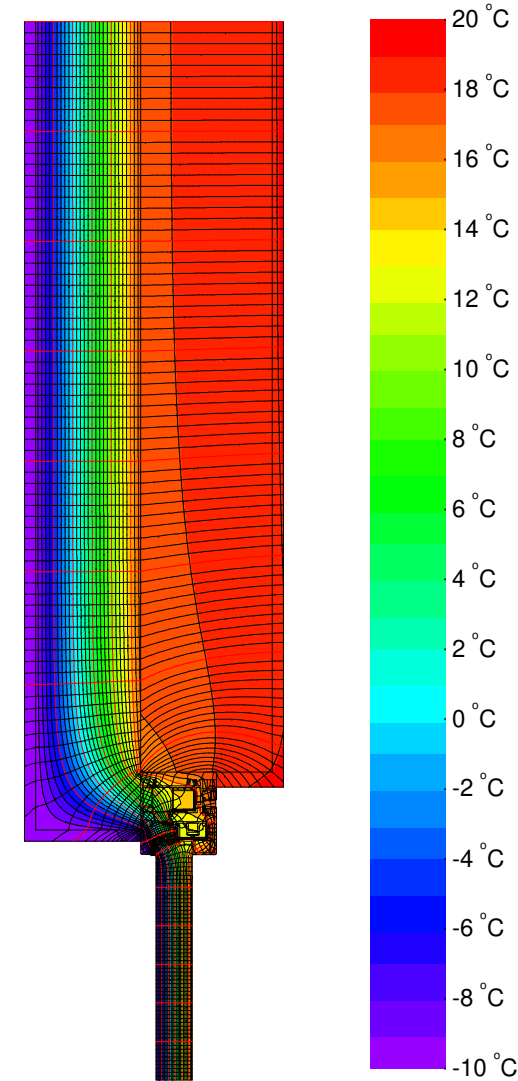
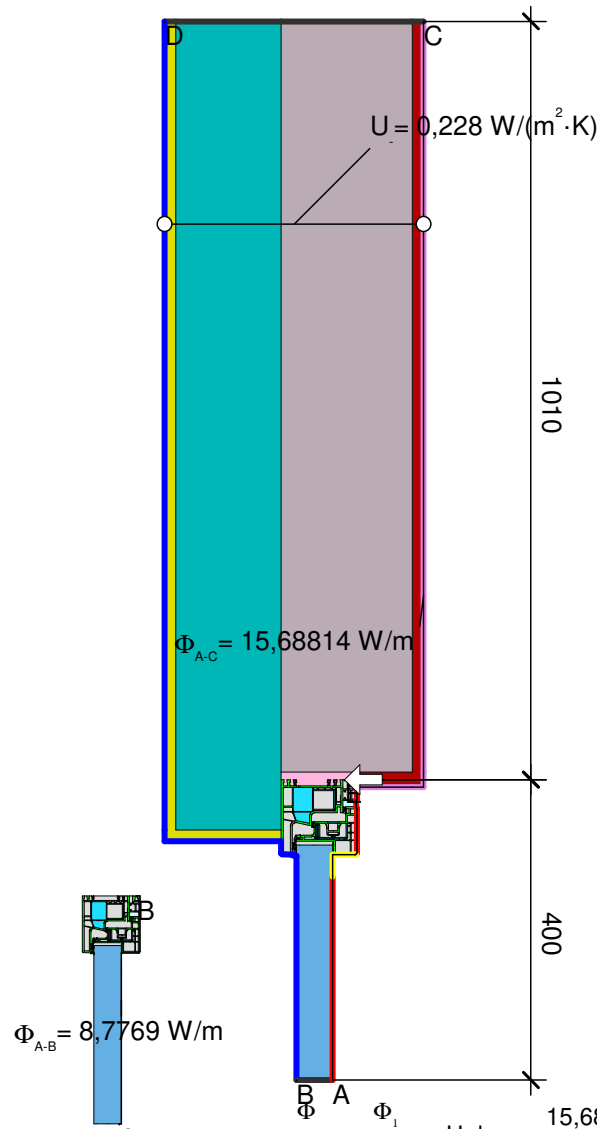
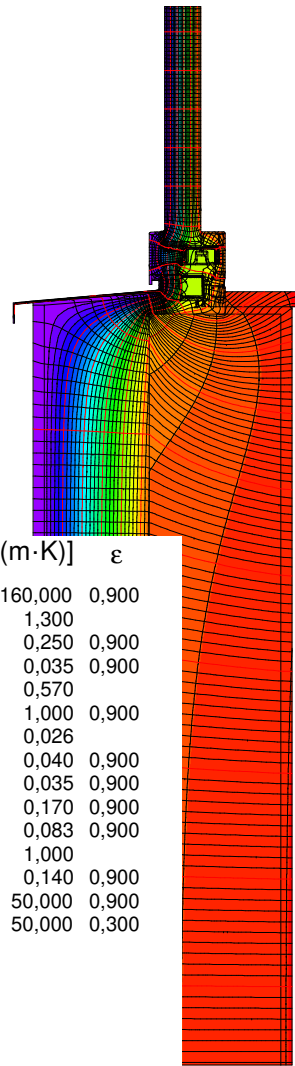

$$\psi_{A-E,C,*} = \frac{\Phi}{\Delta T} - U_1 \cdot b_1 - \frac{\Phi_2}{\Delta T} = \frac{17,384}{30,000} - 0,228 \cdot 1,010 - \frac{8,986}{30,000} = 0,050 \text{ W}/(\text{m} \cdot \text{K})$$

$$\psi_{A-E,C,*} = \frac{\Phi}{\Delta T} - \frac{\Phi_1}{\Delta T} - U_2 \cdot b_2 = \frac{15,688}{30,000} - \frac{8,777}{30,000} - 0,228 \cdot 1,010 = 0,000 \text{ W}/(\text{m} \cdot \text{K})$$

Randbedingung	q [W/m ²]	θ [°C]	R [(m ² ·K)/W]	ϵ
■ Adiabatic Adiatat	0,000			
■ Exterior Außen		-10,000	0,040	
■ Interior Innen		20,000	0,130	
■ Interior, frame, normal		20,000	0,130	
■ Interior, frame, reduced		20,000	0,200	
■ e 0,3 Cavity in metal				0,300
■ e 0,9 Cavity Hohlraum				0,900



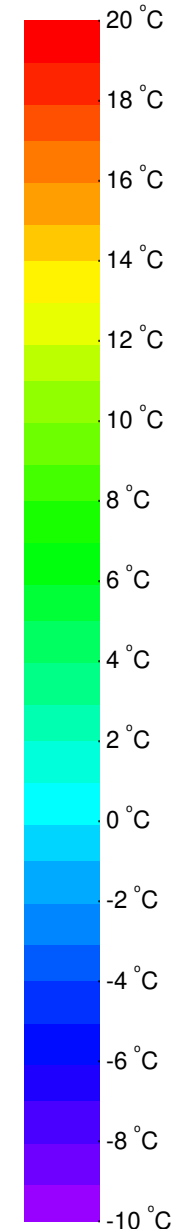
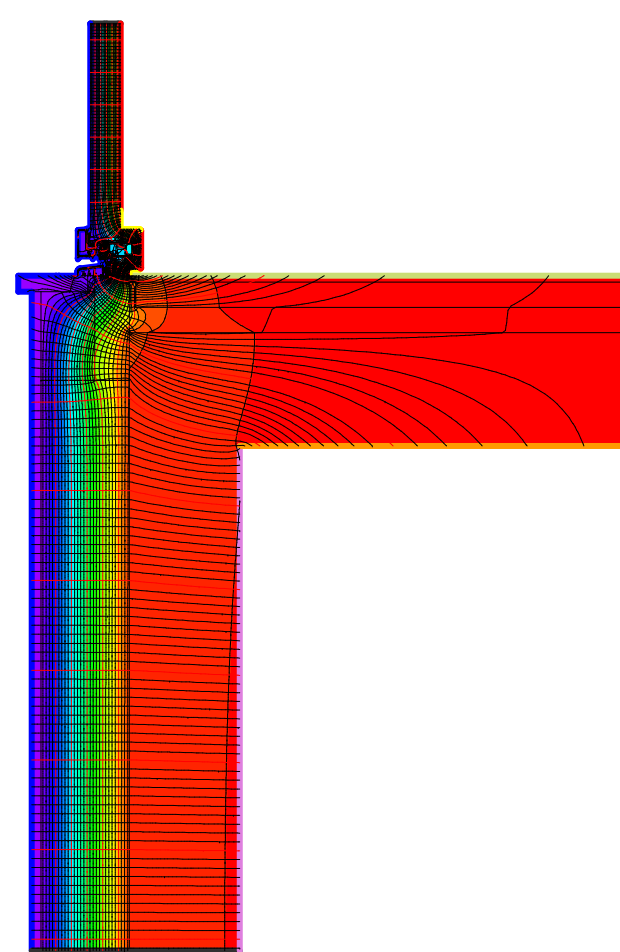
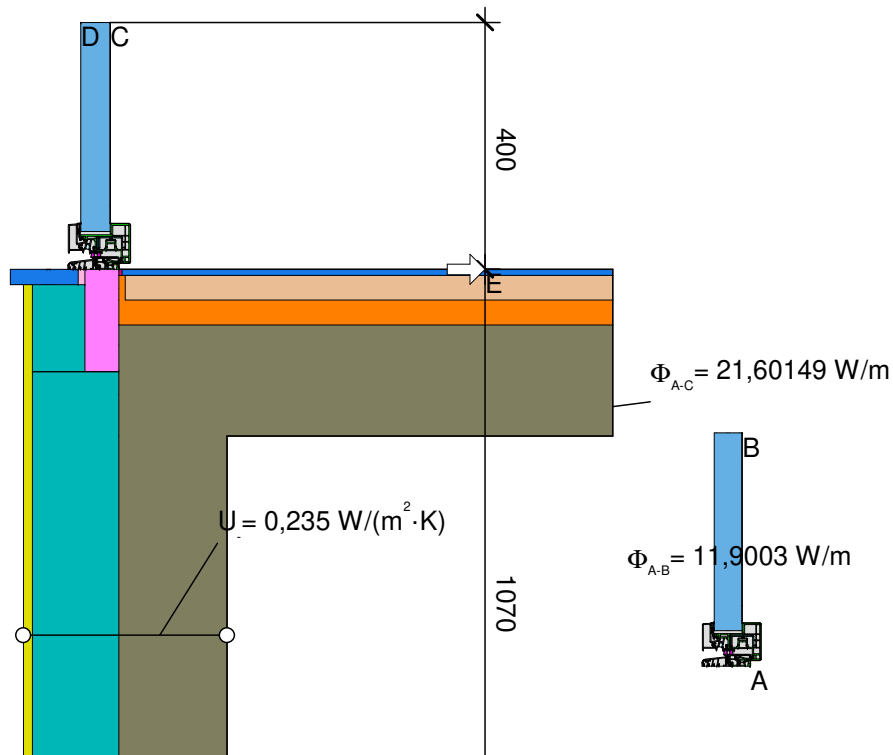

Material	λ [W/(m·K)]	ϵ
Aluminum Aluminium 10456	160,000	0,900
Artificial stone Kunststein 10456	1,300	0,900
Bürstendichtung (polyesterbeschichtetes Mohair)	0,140	0,900
Cement screed Zement-Estrich 4108	1,400	
Concrete, 1% Steel Beton, 1% Stahl 10456	2,300	
EPDM	0,250	0,900
Insulation Wärmedämmung 035	0,035	
Insulation Wärmedämmung 040	0,040	
Lime-cement plaster Kalkzementputz ISO 10456	1,000	
PU in-situ foam PU-Ortschaum 040	0,040	0,900
Panel Maske	0,035	0,900
Polyvinylchloride (PVC)	0,170	0,900
Purenit 500 M	0,086	0,900
STV-Klebeband	0,083	0,900
Silicone Silikon	0,350	
Soft PVC Weich-PVC	0,140	0,900
Steel Stahl	50,000	0,900
Unbelüftete Hohlräume **		
Unvent. cavity unbel. Hohlr. **		
slightly vent. cav. leicht bel. Hohlr. **		

** EN ISO 10077-2:2017, 6.4.3

$$\psi_{A-E.C.} = \frac{\Phi}{\Delta T} - U_1 \cdot b_1 - \frac{\Phi_2}{\Delta T} = \frac{21,601}{30,000} - 0,235 \cdot 1,070 - \frac{11,900}{30,000} = 0,072 \text{ W/(m} \cdot \text{K)}$$

Randbedingung	q [W/m ²]	θ [°C]	R [(m ² ·K)/W]	ϵ
Adiabatic Adiat	0,000			
Exterior Außen		-10,000	0,040	
Int. flux down Innen abwärts		20,000	0,170	
Interior up. Innen auf.		20,000	0,100	
Interior Innen		20,000	0,130	
Interior, frame, normal		20,000	0,130	
Interior, frame, reduced		20,000	0,200	
e 0,9 Cavity Hohlraum				0,900



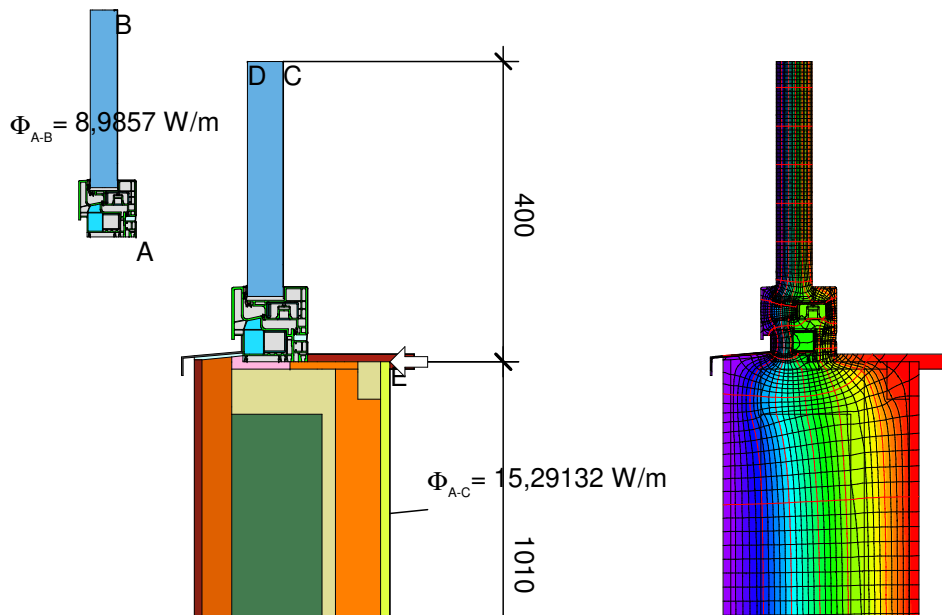

Material	λ [W/(m·K)]	ϵ
Aluminum Aluminium 10456	160,000	0,900
EPDM	0,250	0,900
Gipskartonplatten 900 kg/m ³ 10456	0,250	
Holzweichfaserplatte	0,050	0,900
Insulation Wärmedämmung 040	0,040	0,900
Kunstharzputz 4108-4	0,700	0,900
Nutzholz 500 kg/m ³ , auch OSB 10456	0,130	
Nutzholz 700 kg/m ³ 10456	0,180	
PU foam 0,021*1.25	0,026	
PUR-Ortschaum WLG 040	0,040	0,900
Panel Maske	0,035	0,900
Polyvinylchloride (PVC)	0,170	0,900
STV-Klebeband	0,083	0,900
Soft PVC Weich-PVC	0,140	0,900
Steel Stahl	50,000	0,900
Steel Stahl	50,000	0,300
Unvent. cavity unbel. Hohlr. **		
Wärmedämmung 040	0,040	
Zellulose 040	0,040	
slightly vent. cav. leicht bel. Hohlr. **		

** EN ISO 10077-2:2017, 6.4.3

Randbedingung	q [W/m ²]	θ [°C]	R [(m ² ·K)/W]	ϵ
Adiabatic Adiatat	0,000			
Exterior Außen		-10,000	0,040	
Interior Innen		20,000	0,130	
Interior, frame, normal		20,000	0,130	
Interior, frame, reduced		20,000	0,200	
e 0,3 Cavity in metal				0,300
e 0,9 Cavity Hohlräum				0,900

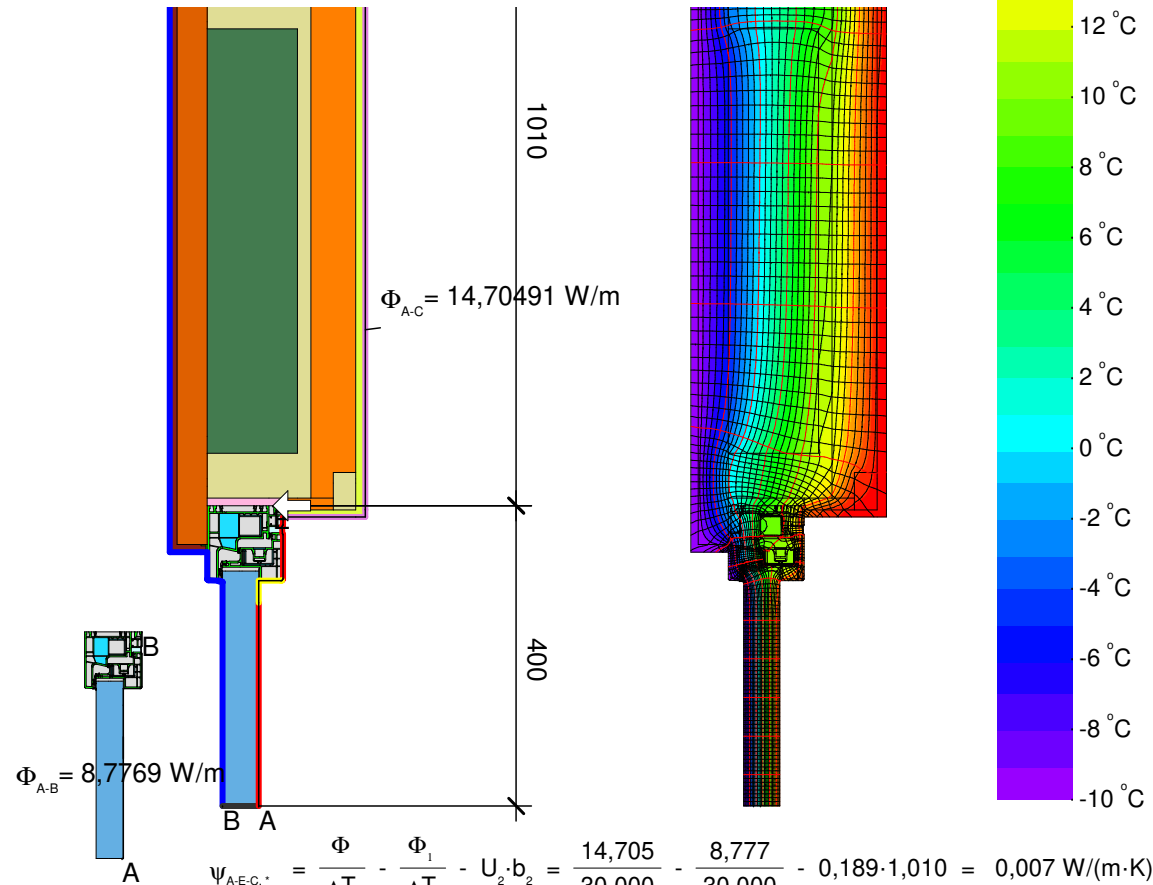

$$\psi_{A-E,C,*} = \frac{\Phi}{\Delta T} - U_1 \cdot b_1 - \frac{\Phi_2}{\Delta T} = \frac{15,291}{30,000} - 0,189 \cdot 1,010 - \frac{8,986}{30,000} = 0,020 \text{ W}/(\text{m} \cdot \text{K})$$

$$\psi_{A-E,C,*} = \frac{\Phi}{\Delta T} - \frac{\Phi_1}{\Delta T} - U_2 \cdot b_2 = \frac{14,705}{30,000} - \frac{8,777}{30,000} - 0,189 \cdot 1,010 = 0,007 \text{ W}/(\text{m} \cdot \text{K})$$

$$U_{eq A-B} = \frac{\Phi}{\Delta T \cdot b} = \frac{3,903}{30,000 \cdot 0,690} = 0,189 \text{ W}/(\text{m}^2 \cdot \text{K})$$

$$\Phi_{A-B} = 3,90321 \text{ W/m}$$



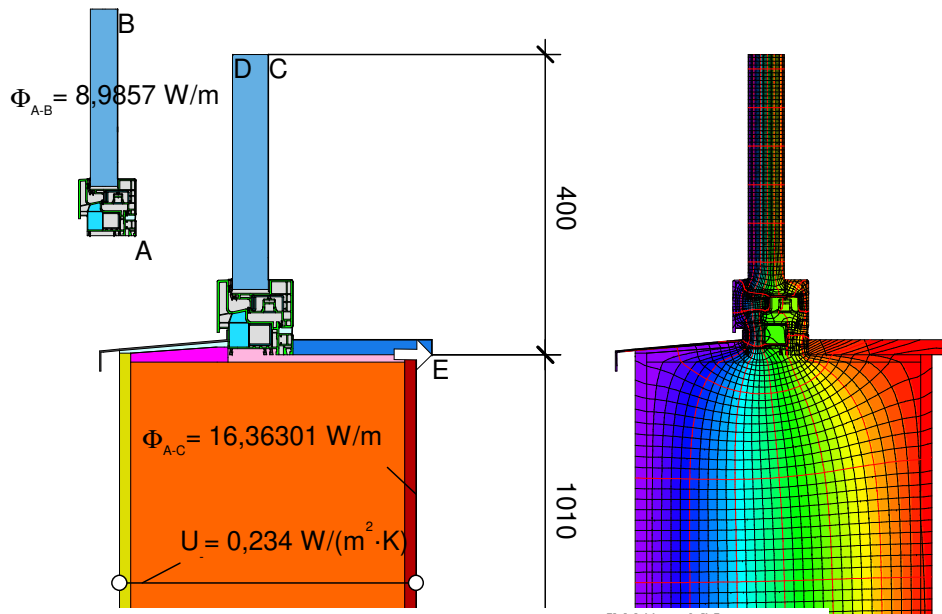

Material	λ [W/(m·K)]	ϵ
Aluminum Aluminium 10456	160,000	0,900
Artificial stone Kunststein 10456	1,300	
EPDM	0,250	0,900
Hollow brick Hochlochziegel 0.09	0,090	
Insulation Wärmedämmung 032	0,032	0,900
Interior plaster Gipsputz 10456	0,570	
Lime-cement plaster Kalkzementputz ISO 10456	1,000	0,900
PU foam 0,021*1.25 (5)	0,026	
PU in-situ foam PU-Ortschaum 040	0,040	0,900
Panel Maske	0,035	0,900
Polyvinylchloride (PVC)	0,170	0,900
STV-Klebeband	0,083	0,900
Soft PVC Weich-PVC	0,140	0,900
Steel Stahl	50,000	0,900
Steel Stahl	50,000	0,300
Unvent. cavity unbel. Hohlr. **		
slightly vent. cav. leicht bel. Hohlr. **		

** EN ISO 10077-2:2017, 6.4.3

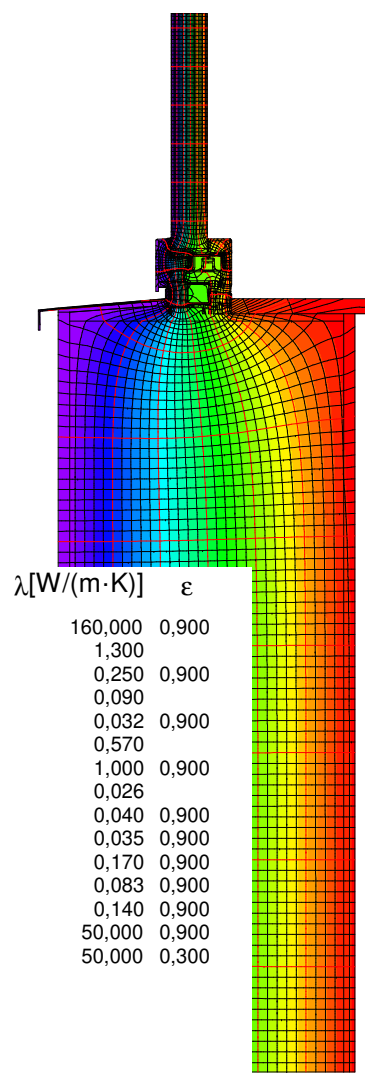

Randbedingung	q [W/m²]	θ [°C]	R [(m²·K)/W]	ϵ
Adiabatic Adiat	0,000			
Exterior Außen		-10,000	0,040	
Interior Innen		20,000	0,130	
Interior, frame, normal		20,000	0,130	
Interior, frame, reduced		20,000	0,200	
e 0,3 Cavity in metal				0,300
e 0,9 Cavity Hohlraum				0,900

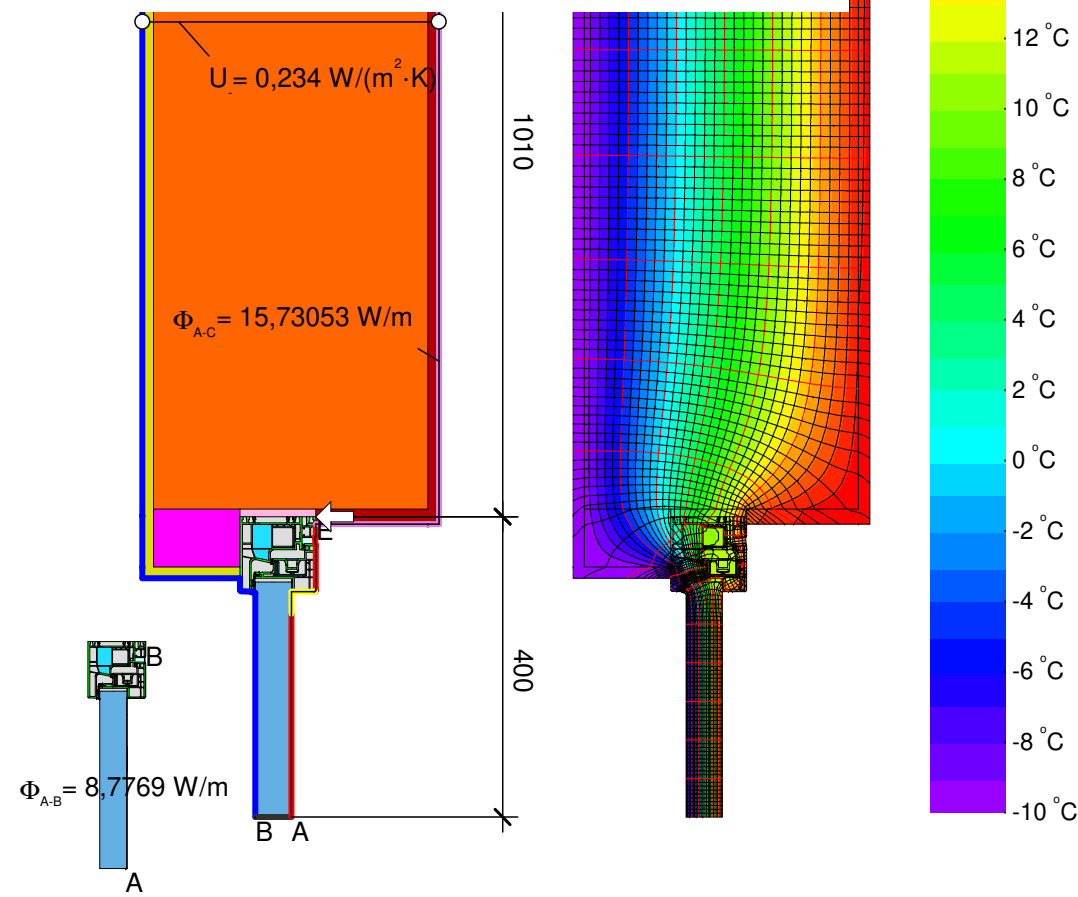

$$\psi_{A-E,C,*} = \frac{\Phi}{\Delta T} - U_1 \cdot b_1 - \frac{\Phi_2}{\Delta T} = \frac{16,363}{30,000} - 0,234 \cdot 1,010 - \frac{8,986}{30,000} = 0,009 \text{ W/(m·K)}$$

$$\psi_{A-E,C,*} = \frac{\Phi}{\Delta T} - \frac{\Phi_1}{\Delta T} - U_2 \cdot b_2 = \frac{15,731}{30,000} - \frac{8,777}{30,000} - 0,234 \cdot 1,010 = -0,005 \text{ W/(m·K)}$$

