

# 证书

被动房已认证组件

组件认证编码 2124wi03 有效至 31st December 2025

Passive House Institute  
Dr. Wolfgang Feist  
64283 Darmstadt  
Germany

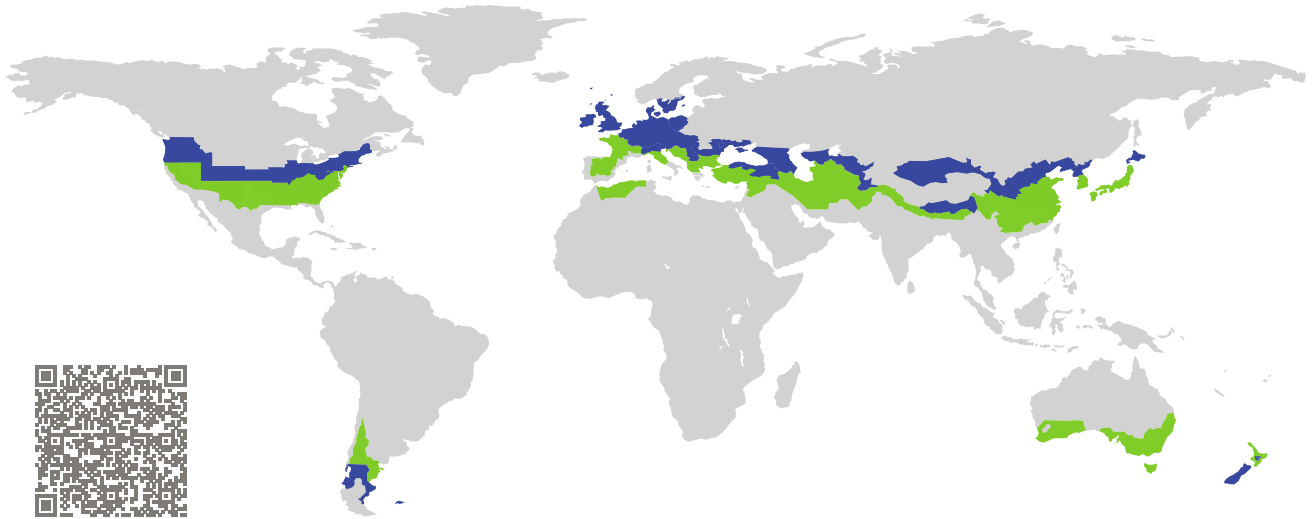

类别: 窗框  
制造商: 青岛宏海绿能有限公司  
**Qing Dao Hong Hai Green Energy Co. LTD,**  
**qingdao,**  
**China**  
产品名称: **HHGR105W**

此证书根据以下规格颁发, 适用于凉温气候带 (**cool temperate**)

舒适度  $U_W = 0.79 \leq 0.80 \text{ W}/(\text{m}^2 \text{ K})$   
 $U_{W, \text{installed}} \leq 0.85 \text{ W}/(\text{m}^2 \text{ K})$   
with  $U_g = 0.70 \text{ W}/(\text{m}^2 \text{ K})$

卫生标准  $f_{Rsi=0.25} \geq 0.70$

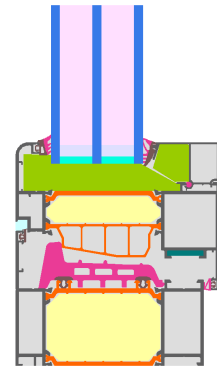

被动房  
节能等级

phE

phD

phC

phB

phA

cool, temperate climate



**CERTIFIED  
COMPONENT**

Passive House Institute

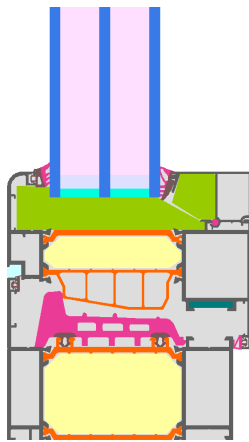

计算模型

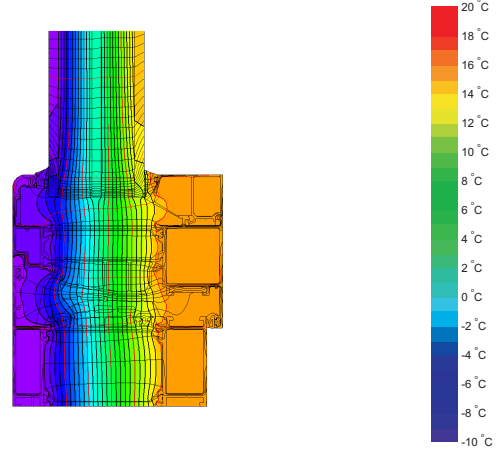

等温线图

### 认证产品描述

铝框保温隔热 (low lambda PA 0.21 W/(mK)) 隔热 (Kooltherm 0.022 W/(mK) , PE foam 0.038 W/(mK));  
窗厚: 51 mm (5/18/5/18/5); 槽口: 17 mm; 间隔条 Swisspacer Ultimate; 双层密封 Butyl

### 说明





整窗U值是基于参照尺寸 1.23 m × 1.48 m with  $U_g = 0.70 \text{ W}/(\text{m}^2 \text{ K})$ . 若使用更高品质的节能玻璃, 整窗U值可提升如下:

玻璃	$U_g =$	0.70	0.64	0.58	0.54	$\text{W}/(\text{m}^2 \text{ K})$
		↓	↓	↓	↓	
整窗	$U_w =$	0.79	0.75	0.71	0.69	$\text{W}/(\text{m}^2 \text{ K})$

建筑透明组件通过非透明部份的传热损失进行节能分级。整窗传热损失包括由窗框U值和窗框宽度, 暖边热桥和暖边长度引起的热损失。详细计算可从制造商获取。

被动房研究所将国际组件认证标准划分为七种气候类型。原则上, 满足更高节能要求的认证组件也可用于节能要求较低的气候区。在特定气候区中, 使用具有高节能要求的认证组件会更具有意义。

更多认证信息: [www.passivehouse.com](http://www.passivehouse.com) and [passipedia.org](http://passipedia.org).

窗框参数		宽度 $b_f$ mm	$U$ -值 $U_f$ W/(m <sup>2</sup> K)	暖边热桥- $\Psi$ -值 $\Psi_g$ W/(m K)	温度系数 (卫生标准) $f_{RSi=0.25}$ [-]
横梁1	(1T1) 	146	0.81	0.023	0.75
下横框	(OB1) 	124	0.81	0.023	0.76
上横框	(OH1) 	124	0.81	0.023	0.76
侧面	(OJ1) 	124	0.81	0.023	0.76
暖边间隔条: SWISSPACER ULTIMATE				双层密封胶: Butyl	

# 安装节点

