

CERTIFICATE

Certified Passive House Component

Component-ID 1705ds03 valid until 31st December 2025

Passive House Institute
Dr. Wolfgang Feist
64283 Darmstadt
Germany

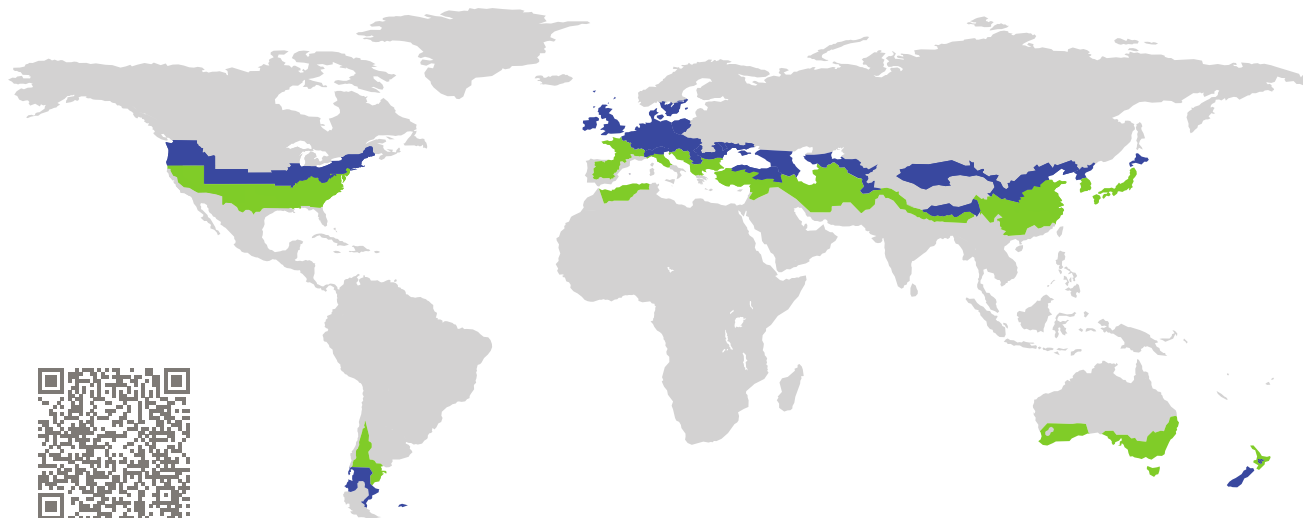

Category: **Door system**
Manufacturer: **NEOS Protect Ltd.**
Newcastle
United Kingdom
Product name: **NEOS HI System**

This certificate was awarded based on the following criteria for the cool, temperate climate zone

Comfort $U_D = 0.75 \leq 0.80 \text{ W}/(\text{m}^2 \text{ K})$
 $U_{D, \text{installed}} \leq 0.85 \text{ W}/(\text{m}^2 \text{ K})$
with $U_{\text{door leaf}}^1 = 0.30 \text{ W}/(\text{m}^2 \text{ K})$

Hygiene $f_{Rsi=0.25} \geq 0.70$
Airtightness $Q_{100} = 2.25 \leq 2.25 \text{ m}^3/(\text{h m})$

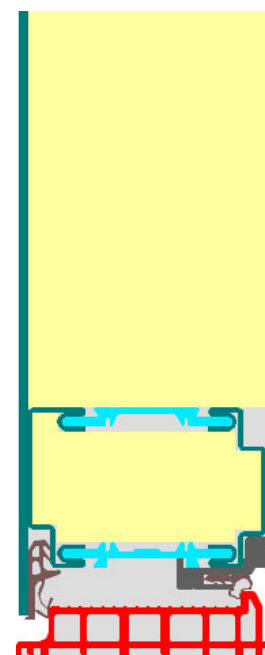

(Outward open)

¹U-value of the insulated area of door leaf

cool, temperate climate



**CERTIFIED
COMPONENT**

Passive House Institute

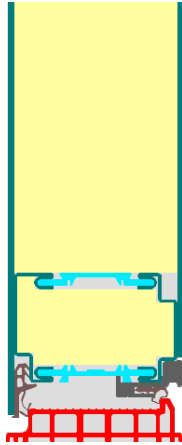

Calculation model

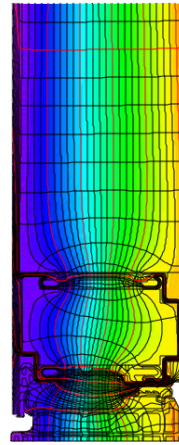

Isothermal

Description

Steel frame with phenolic foam insulation (Kingspan Kooltherm, 0,023 W/(mK)). Sidelight glazing 4/18/4/18/4 mm, vision panel glazing 11,5/18/0,38/18/6,4 mm. Spacer: SuperSpacer Premium with butyl secondary seal. Airtightness class 4 according to EN 12207 is achieved.

Explanation





The U-values of the door apply to a combination of door and sidelight with fixed glazing, 2.20 m wide by 2.20 m tall. The door and the sidelight are both 1.10 m wide.

A detailed report of the calculations performed in the context of certification is available from the manufacturer.

Unless stated otherwise, the air tightness was determined according to EN 1026 with respect to the joint length under climate load in conjunction with EN 1121 for the closed, non-locked door. The result corresponds at least to air-tightness class 3 according to EN 12207.

The Passive House Institute has defined international component criteria for seven climate zones. In principle, components which have been certified for climate zones with higher requirements may also be used in climates with less stringent requirements. In a particular climate zone it may make sense to use a component of a higher thermal quality which has been certified for a climate zone with more stringent requirements.

Further information relating to certification can be found on www.passivehouse.com and passipedia.org.

Frame values		Frame width b_f mm	U -value frame U_f W/(m ² K)	Ψ edge Ψ_g W/(m K)	Temp. Factor $f_{Rsi=0.25}$ [-]
Mullion 1 casement	(1M1) 	201	1.43	0.025	0.74
Door hinge side	(DJ1) 	110	1.51	0.009	0.77
Door lock side	(DL1) 	111	1.83	0.016	0.74
Bottom fixed	(FB1) 	90	0.84	0.033	0.75
Top fixed	(FH1) 	90	0.84	0.033	0.75
Lateral fixed	(FJ1) 	90	0.84	0.033	0.75
Top	(OH1) 	110	1.50	0.010	0.86
Threshold	(OT2) 	77	1.83	0.018	0.80
		Spacer:	Secondary seal:		



Mullion
1 casement

$b_f = 201$ mm
 $U_f = 1.43$ W/(m² K)
 $\Psi_g = 0.025$ W/(m K)
 $f_{Rsi} = 0.74$



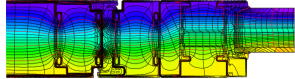





Door
hinge side

$b_f = 110$ mm
 $U_f = 1.51$ W/(m² K)
 $\Psi_g = 0.009$ W/(m K)
 $f_{Rsi} = 0.77$

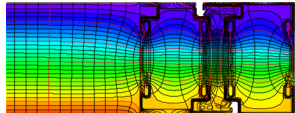





Door
lock side

$b_f = 111$ mm
 $U_f = 1.83$ W/(m² K)
 $\Psi_g = 0.016$ W/(m K)
 $f_{Rsi} = 0.74$

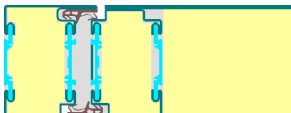

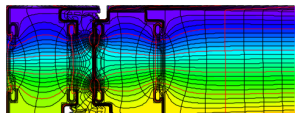



Bottom fixed

$$b_f = 90 \text{ mm}$$

$$U_f = 0.84 \text{ W/(m}^2 \text{ K)}$$

$$\Psi_g = 0.033 \text{ W/(m K)}$$

$$f_{Rsi} = 0.75$$

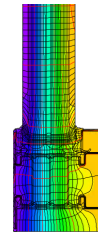
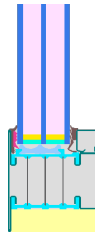

Top fixed

$$b_f = 90 \text{ mm}$$

$$U_f = 0.84 \text{ W/(m}^2 \text{ K)}$$

$$\Psi_g = 0.033 \text{ W/(m K)}$$

$$f_{Rsi} = 0.75$$

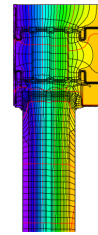
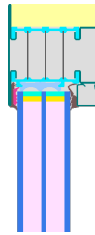

Lateral fixed

$$b_f = 90 \text{ mm}$$

$$U_f = 0.84 \text{ W/(m}^2 \text{ K)}$$

$$\Psi_g = 0.033 \text{ W/(m K)}$$

$$f_{Rsi} = 0.75$$

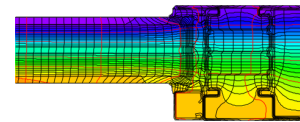
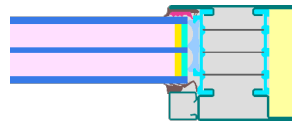

Top

$$b_f = 110 \text{ mm}$$

$$U_f = 1.50 \text{ W/(m}^2 \text{ K)}$$

$$\Psi_g = 0.010 \text{ W/(m K)}$$

$$f_{Rsi} = 0.86$$

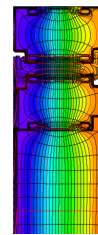
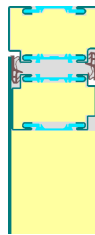

Threshold

$$b_f = 77 \text{ mm}$$

$$U_f = 1.83 \text{ W/(m}^2 \text{ K)}$$

$$\Psi_g = 0.018 \text{ W/(m K)}$$

$$f_{Rsi} = 0.80$$

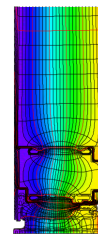

Glazing/Infill: 1

$$U_p = 0.50 \text{ W/(m}^2 \text{ K)}$$

$$\Psi = 0.075 \text{ W/(m K)}$$

$$f_{Rsi} = 0.82$$

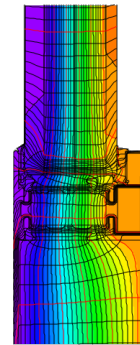
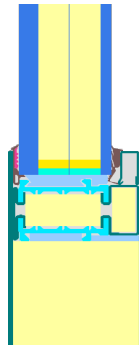

Description:

Glazing (11,5/18/0,38/18/6,4) with $U_g = 0,50 \text{ W/(m}^2\text{K)}$ in accordance with EN 673; Spacer 'SuperSpacer Premium' with butyl secondary seal.

The comfort criterion limits the use of the infill element as follows:

Maximum area= 0.14 m^2

Maximum circumference= 1.96 m

Validated installations

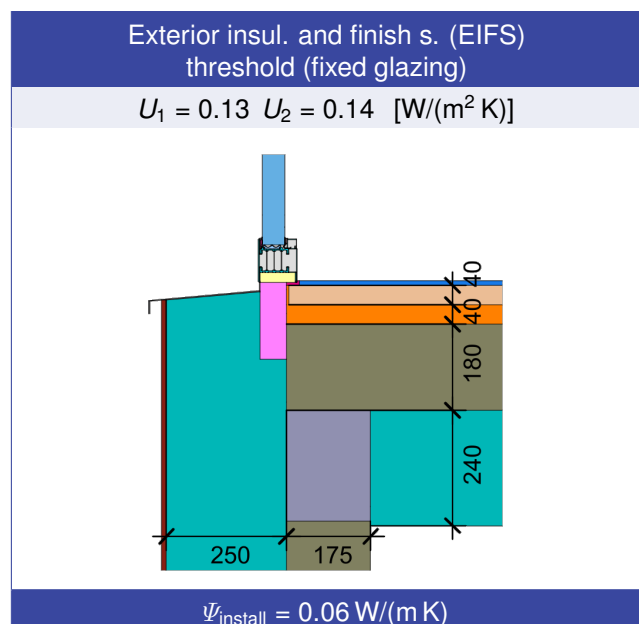
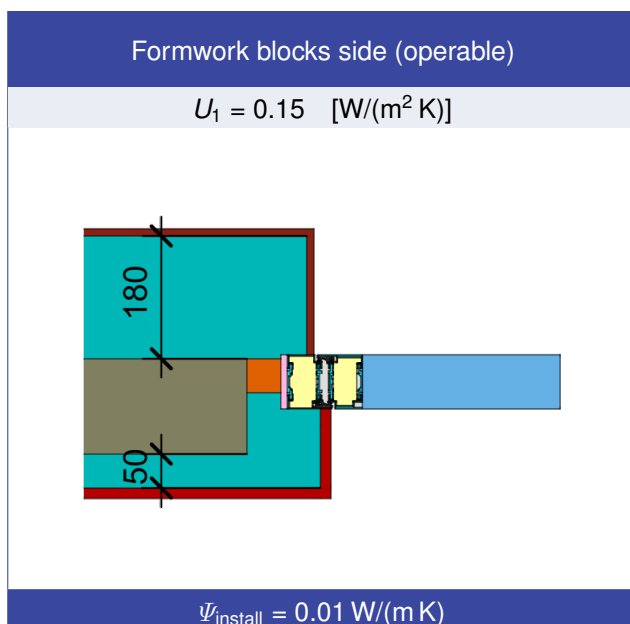
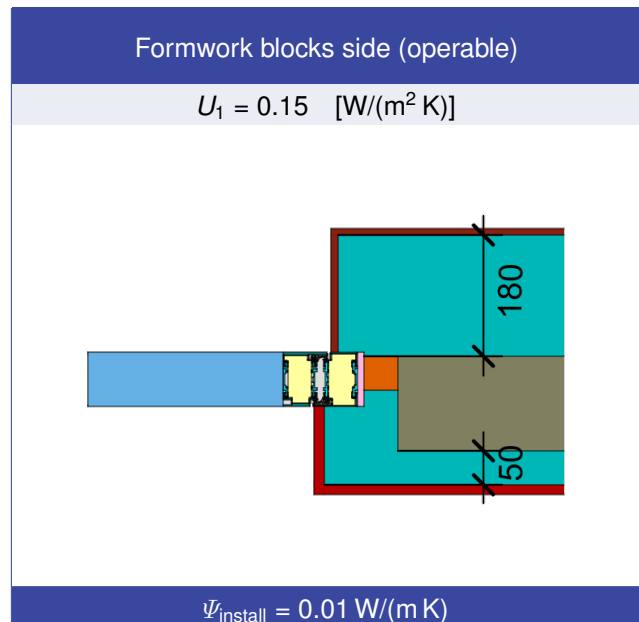
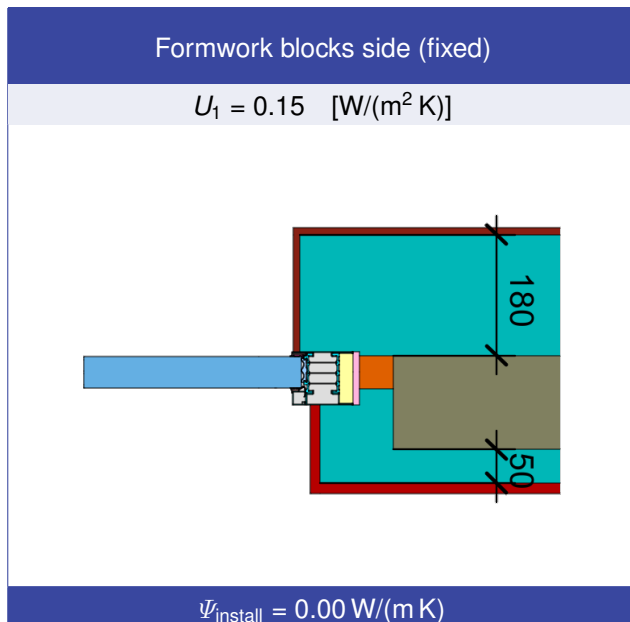
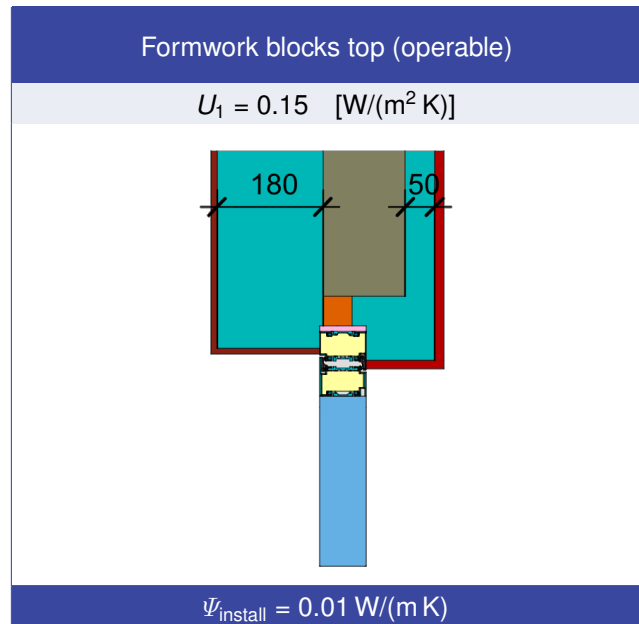
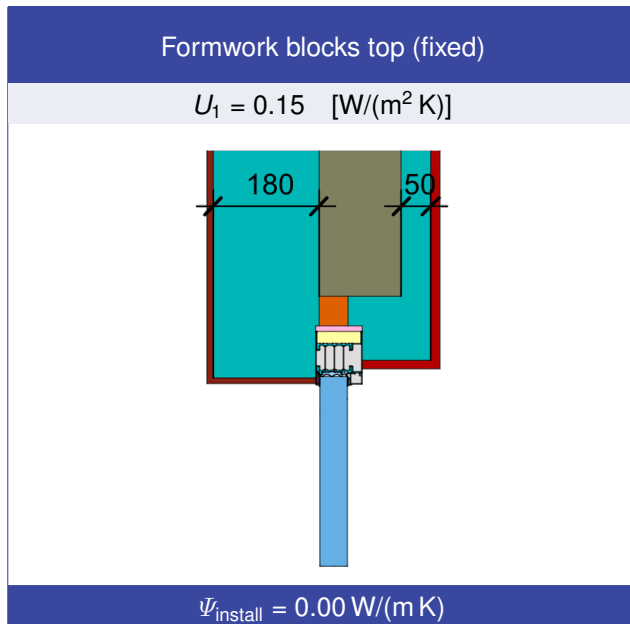

Ext. ins. a. finish. s. (EIFS) threshold floor slab (fixed gl.)

$U_1 = 0.13 \quad U_2 = 0.14 \quad [W/(m^2 K)]$

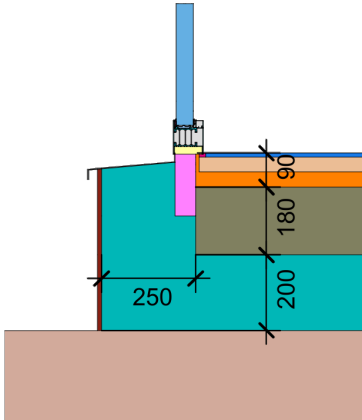

$\Psi_{\text{install}} = 0.05 \text{ W/(m K)}$

Lightweight timber top (fixed glazed)

$U_1 = 0.13 \quad [W/(m^2 K)]$

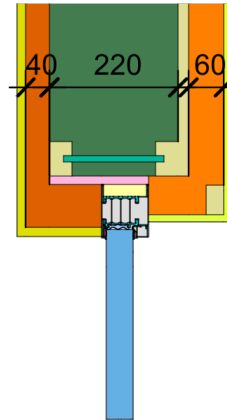

$\Psi_{\text{install}} = 0.00 \text{ W/(m K)}$

Lightweight timber top (operable)

$U_1 = 0.13 \quad [W/(m^2 K)]$

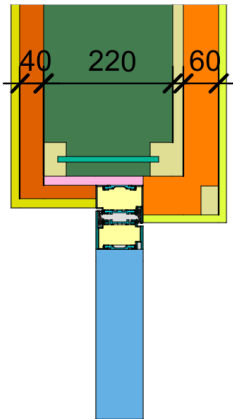

$\Psi_{\text{install}} = 0.00 \text{ W/(m K)}$

Lightweight timber side (fixed glazed)

$U_1 = 0.13 \quad [W/(m^2 K)]$

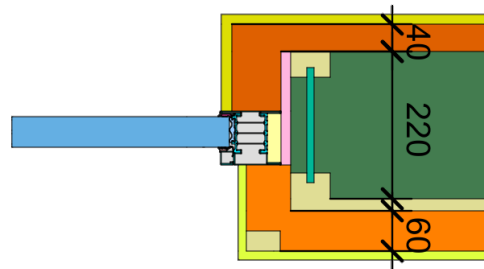

$\Psi_{\text{install}} = 0.00 \text{ W/(m K)}$

Lightweight timber side (operable)

$U_1 = 0.13 \quad [W/(m^2 K)]$

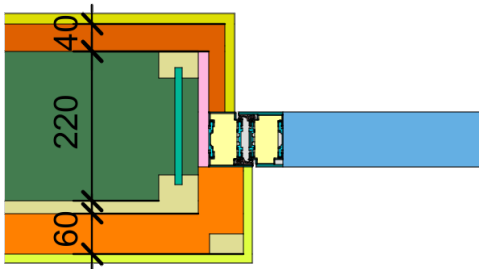

$\Psi_{\text{install}} = -0.01 \text{ W/(m K)}$

Lightweight timber side (operable)

$U_1 = 0.13 \quad [W/(m^2 K)]$

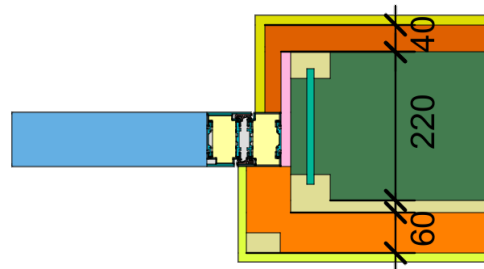

$\Psi_{\text{install}} = -0.00 \text{ W/(m K)}$

Exterior insulation and finishing s (EIFS)
top (fixed glazing)

$$U_1 = 0.11 \text{ [W/(m}^2 \text{ K)]}$$

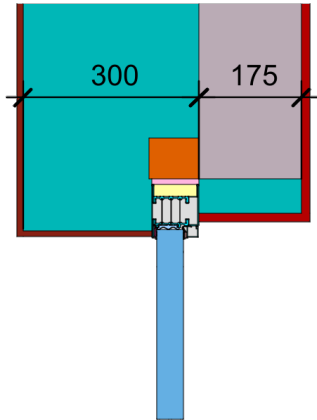

$$\Psi_{\text{install}} = 0.01 \text{ W/(m K)}$$

Exterior insulation and finishing s (EIFS)
top (operable)

$$U_1 = 0.11 \text{ [W/(m}^2 \text{ K)]}$$

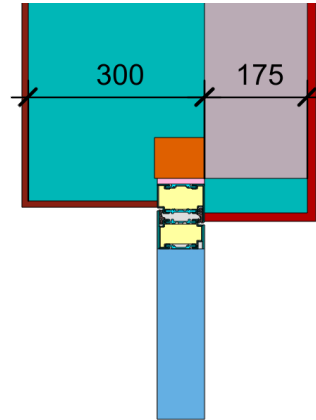

$$\Psi_{\text{install}} = 0.02 \text{ W/(m K)}$$

Ext. ins. a. finish. s. (EIFS) threshold
floor slab (operable)

$$U_1 = 0.13 \quad U_2 = 0.14 \text{ [W/(m}^2 \text{ K)]}$$

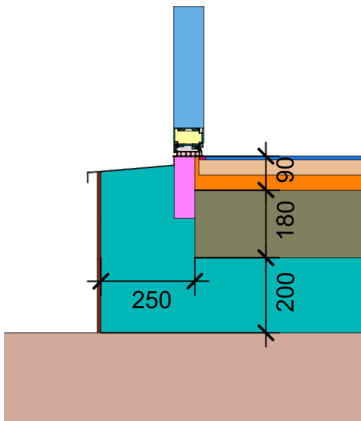

$$\Psi_{\text{install}} = 0.05 \text{ W/(m K)}$$

Ext insulation a. finish. s. (EIFS)
threshold ceiling (operable)

$$U_1 = 0.14 \text{ [W/(m}^2 \text{ K)]}$$

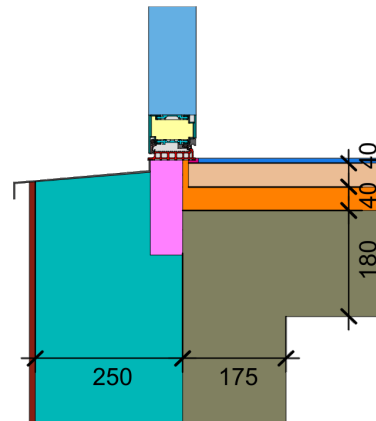

$$\Psi_{\text{install}} = 0.07 \text{ W/(m K)}$$

Ext insulation a. finish. s. (EIFS)
threshold ceiling (fixed gl)

$$U_1 = 0.14 \text{ [W/(m}^2 \text{ K)]}$$

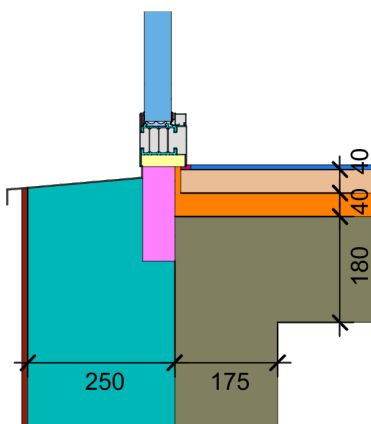

$$\Psi_{\text{install}} = 0.07 \text{ W/(m K)}$$

Exterior insulation and finishing s (EIFS)
threshold (operable)

$$U_1 = 0.13 \quad U_2 = 0.14 \text{ [W/(m}^2 \text{ K)]}$$

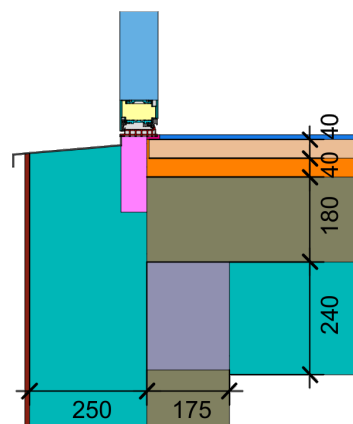

$$\Psi_{\text{install}} = 0.06 \text{ W/(m K)}$$

Exterior insulation and finishing system (EIFS) side (fixed glazed)

$$U_1 = 0.11 \text{ [W/(m}^2 \text{ K)]}$$

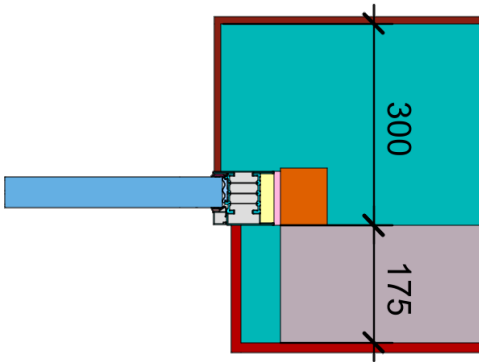

$$\Psi_{\text{install}} = 0.01 \text{ W/(m K)}$$

Exterior insulation and finishing system (EIFS) side (operable)

$$U_1 = 0.11 \text{ [W/(m}^2 \text{ K)]}$$

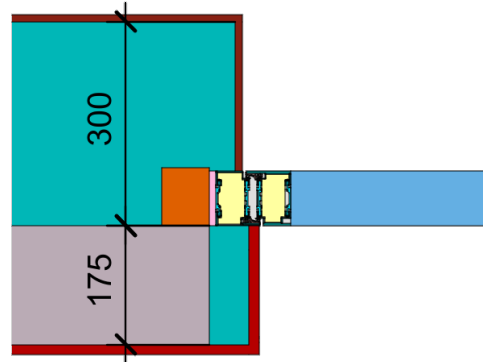

$$\Psi_{\text{install}} = 0.01 \text{ W/(m K)}$$

Exterior insulation and finishing system (EIFS) side (operable)

$$U_1 = 0.11 \text{ [W/(m}^2 \text{ K)]}$$

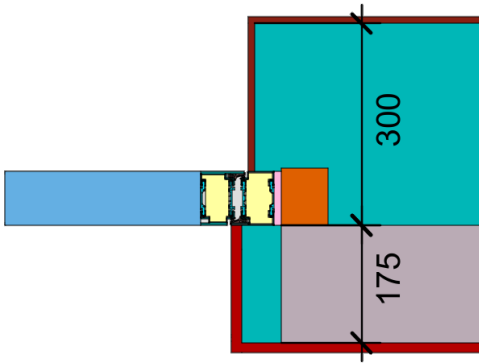

$$\Psi_{\text{install}} = 0.01 \text{ W/(m K)}$$

