

# CERTIFICATE

Certified Passive House Component

Component-ID 0901wi03 valid until 31st December 2025

Passive House Institute  
Dr. Wolfgang Feist  
64283 Darmstadt  
Germany

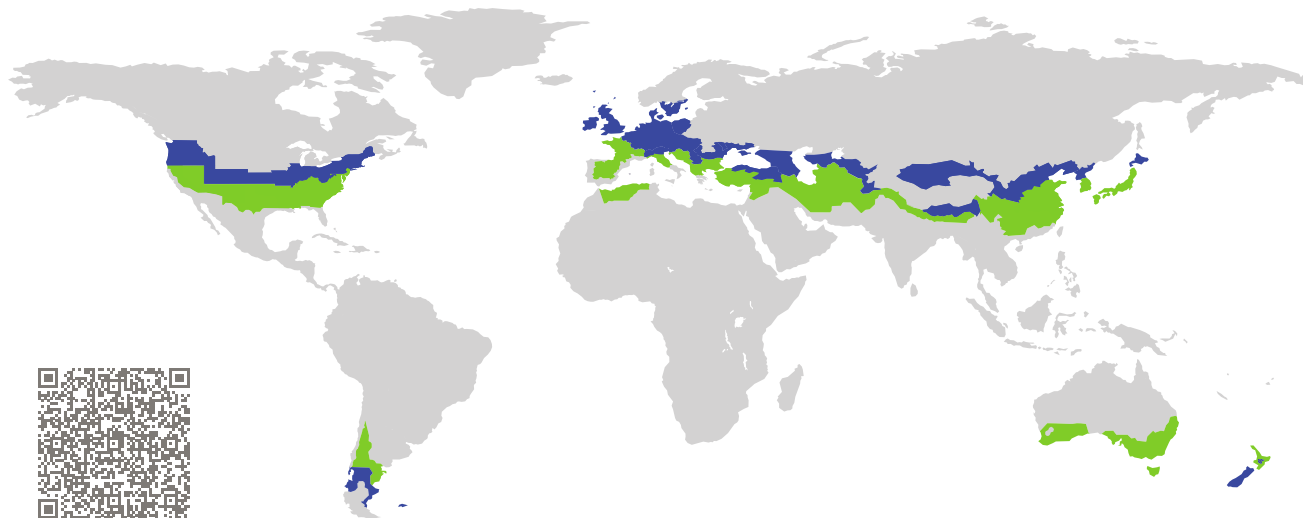

Category: **Window Frame**  
Manufacturer: **Beijing Mylch Building Products Co., Ltd. & Shanghai Mylch Windows and Doors Manufacturing Co., Ltd., BEIJING, China**  
Product name: **M130**

This certificate was awarded based on the following criteria for the cool, temperate climate zone

Comfort  $U_W = 0.78 \leq 0.80 \text{ W}/(\text{m}^2 \text{ K})$   
 $U_{W, \text{installed}} \leq 0.85 \text{ W}/(\text{m}^2 \text{ K})$   
with  $U_g = 0.70 \text{ W}/(\text{m}^2 \text{ K})$

Hygiene  $f_{Rsi=0.25} \geq 0.70$

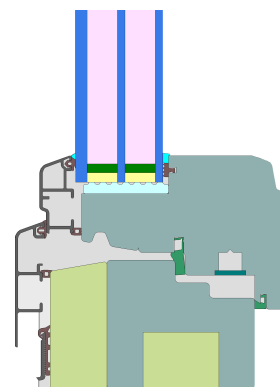

Passive House  
efficiency class

phE

phD

phC

phB

phA

cool, temperate climate



**CERTIFIED  
COMPONENT**

Passive House Institute

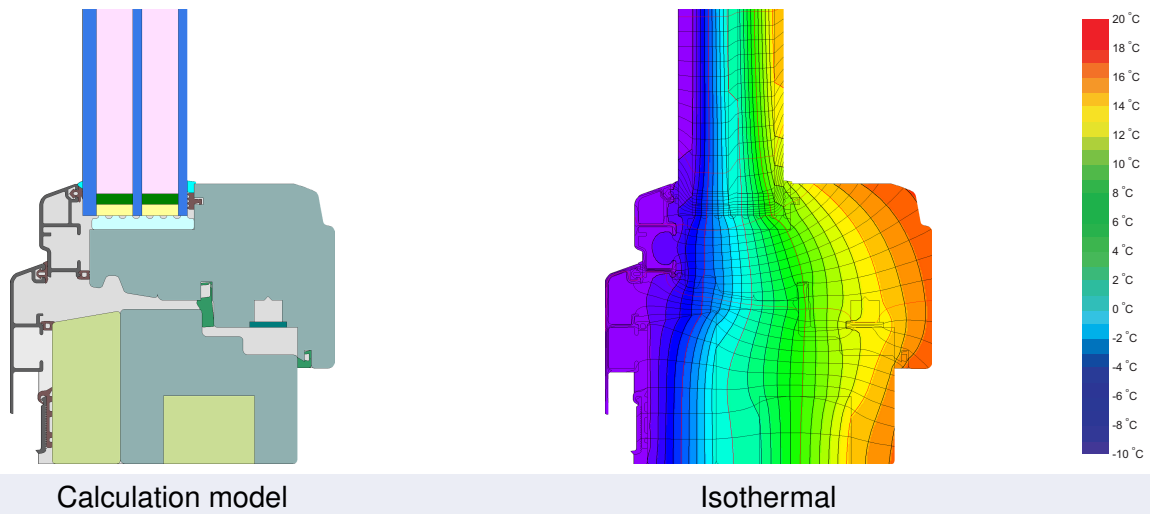

Calculation model Isothermal

### Description

Construction: Timber-Aluminium frame with insulation (0.030 W/(mK)) inside the blind frame. Pane thickness: 46 mm (6/16/4/16/4), rebate depth: 14 mm, spacer: Super Spacer Premium with Butyl-sealing.

### Explanation

The window U-values were calculated for the test window size of 1.23 m × 1.48 m with  $U_g = 0.70$  W/(m<sup>2</sup> K). If a higher quality glazing is used, the window U-values will improve as follows:

Glazing	$U_g =$	0.70	0.64	0.58	0.62	W/(m <sup>2</sup> K)
		↓	↓	↓	↓	
Window	$U_W =$	0.78	0.74	0.70	0.72	W/(m <sup>2</sup> K)







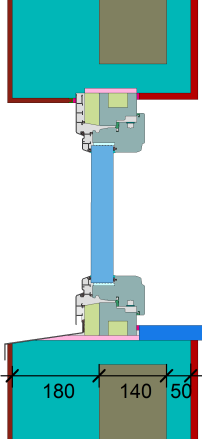
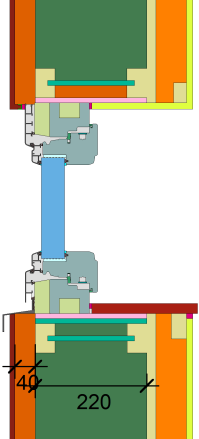
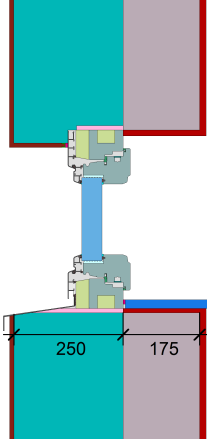

Transparent building components are classified into efficiency classes depending on the heat losses through the opaque part. The frame U-Values, frame widths, thermal bridges at the glazing edge, and the glazing edge lengths are included in these heat losses. A more detailed report of the calculations performed in the context of certification is available from the manufacturer.

The Passive House Institute has defined international component criteria for seven climate zones. In principle, components which have been certified for climate zones with higher requirements may also be used in climates with less stringent requirements. In a particular climate zone it may make sense to use a component of a higher thermal quality which has been certified for a climate zone with more stringent requirements.

Further information relating to certification can be found on [www.passivehouse.com](http://www.passivehouse.com) and [passipedia.org](http://passipedia.org).

## Validated installations

Formwork blocks (operable)	Lightweight timber (operable)	Exterior insulation and finishing system (EIFS) (operable)
$U_{Wall} = 0.15 \text{ W}/(\text{m}^2 \text{ K})$	$U_{Wall} = 0.13 \text{ W}/(\text{m}^2 \text{ K})$	$U_{Wall} = 0.13 \text{ W}/(\text{m}^2 \text{ K})$
		
$\Psi_{install}$ W/(m K)	$\Psi_{install}$ W/(m K)	$\Psi_{install}$ W/(m K)
Top 0.013	Top 0.021	Top 0.010
Side 0.013	Side 0.021	Side 0.010
Bottom 0.015	Bottom 0.028	Bottom 0.011
$U_{W,installed} = 0.82 \text{ W}/(\text{m}^2 \text{ K})$	$U_{W,installed} = 0.84 \text{ W}/(\text{m}^2 \text{ K})$	$U_{W,installed} = 0.81 \text{ W}/(\text{m}^2 \text{ K})$

Frame values		Frame width $b_f$ mm	$U$ -value frame $U_f$ W/(m <sup>2</sup> K)	$\Psi$ -glazing edge $\Psi_g$ W/(m K)	Temp. Factor $f_{Rsi=0.25}$ [-]
Mullion fixed	(0M1) 	120	0.67	0.026	0.72
Mullion 2 casements	(2M1) 	190	0.86	0.024	0.70
Bottom fixed	(FB1) 	88	0.60	0.026	0.71
Top fixed	(FH1) 	88	0.59	0.025	0.71
Lateral fixed	(FJ1) 	88	0.59	0.025	0.71
Bottom	(OB1) 	123	0.76	0.025	0.70
Top	(OH1) 	123	0.75	0.024	0.70
Lateral	(OJ1) 	123	0.75	0.024	0.70
Spacer: Super Spacer Premium			Secondary seal: Butyl		

