

CERTIFICATE

Certified Passive House Component

Component-ID 2158cw03 valid until 31st December 2025

Passive House Institute
Dr. Wolfgang Feist
64283 Darmstadt
Germany

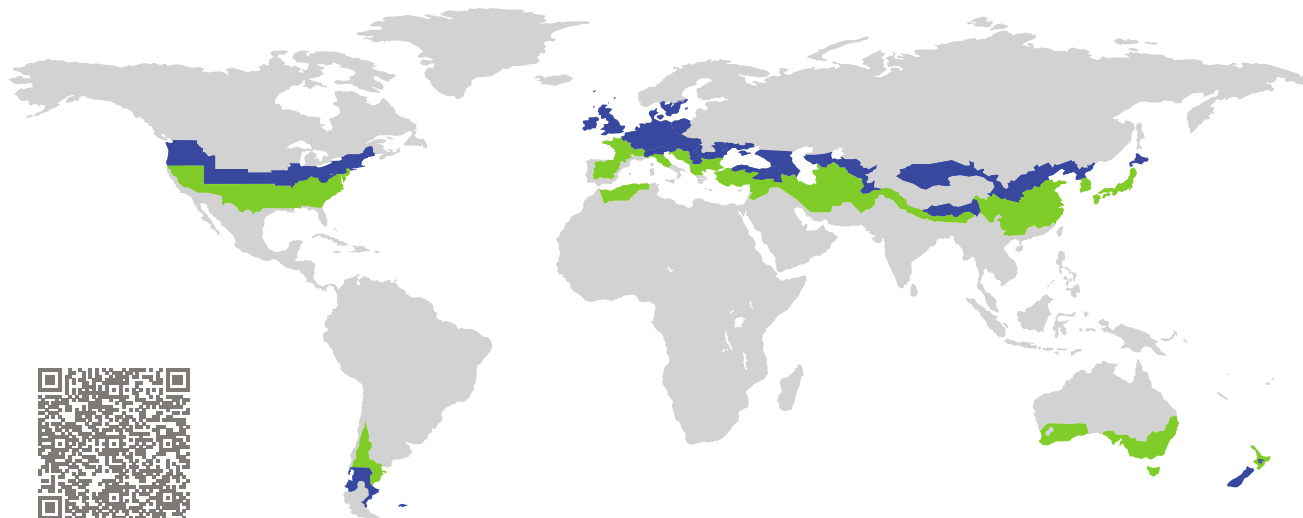

Category: **Curtain Wall**
Manufacturer: **Aluprof S.A.,
Bielsko-Biała,
Poland**
Product name: **MB-MT50N SI**

**This certificate was awarded based on the following
criteria for the cool, temperate climate zone**

Comfort $U_{CW} = 0.79 \leq 0.80 \text{ W}/(\text{m}^2 \text{ K})$
 $U_{CW, \text{installed}} \leq 0.85 \text{ W}/(\text{m}^2 \text{ K})$
with $U_g = 0.70 \text{ W}/(\text{m}^2 \text{ K})$

Hygiene $f_{Rsi=0.25} \geq 0.70$

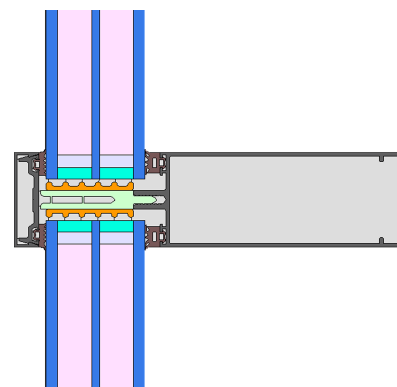

cool, temperate climate



**CERTIFIED
COMPONENT**

Passive House Institute

Passive House
efficiency class

phE

phD

phC

phB

phA

phA+

www.passivehouse.com

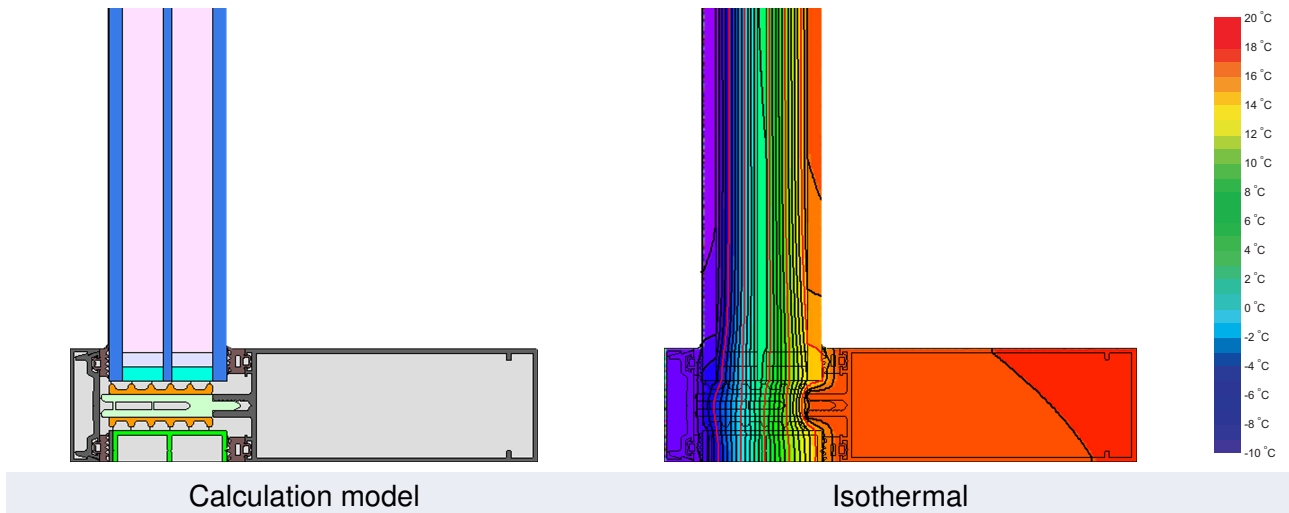

Description

Curtain wall façade system with insulator in the rebate made of XPET (0.029 W/(mK)) and PET (0.038 W/(mK)). Influence of the pressure bar screw connection determined by 3D simulation.

Pane thickness: 52 mm (6/18/4/18/6), rebate depth: 14 mm.

Explanation





The element U-values were calculated for the test element size of 1.20 m × 2.50 m with $U_g = 0.70 \text{ W}/(\text{m}^2 \text{ K})$. If a higher quality glazing is used, the element U-values will improve as follows:

Glazing	$U_g =$	0.70	0.64	0.58	0.54	W/(m ² K)
		↓	↓	↓	↓	
Element	U_{CW}	0.79	0.74	0.68	0.64	W/(m ² K)

Transparent building components are sorted into efficiency classes depending on the heat losses through the opaque part. The frame U-Values, frame widths, thermal bridges at the glazing edge and the glazing edge lengths are included in these heat losses. A more detailed report of the calculations performed in the context of certification is available from the manufacturer.

The Passive House Institute has defined international component criteria for seven climate zones. In principle, components that have been certified for climate zones with higher thermal requirements may also be used in climates with less stringent requirements. In a particular climate zone it may make sense to use a component of a higher thermal quality which has been certified for a climate zone with more stringent requirements.

Further information relating to certification can be found on www.passivehouse.com and passipedia.org.

Frame values			Frame width b_f mm	U -value frame U_f ¹ W/(m ² K)	Ψ -glazing edge Ψ_g W/(m K)	Temp. Factor $f_{Rsi=0.25}$ [-]
Mullion fixed	(OM1)		50	0.86	0.034	0.81
Transom fixed	(OT1)		50	0.86	0.035	0.82
Bottom fixed	(FB1)		50	1.16	0.033	0.80
Top fixed	(FH1)		50	1.15	0.033	0.81
Lateral fixed	(FJ1)		50	1.14	0.033	0.80

Spacer: SWISSPACER ULTIMATE Secondary seal: Butyl

Thermal glass carrier bridge² $\chi_{GT} = 0.004$ W/K

Validated installations

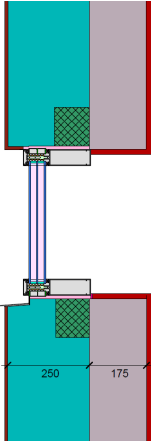
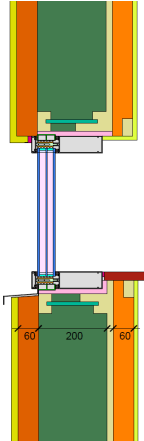
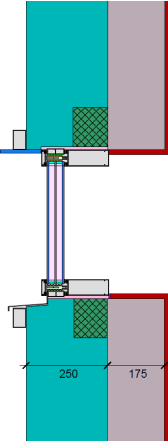
Exterior insulation and finishing system		lightweight timber		Ventilated facade	
$U_{Wall} = 0.13$ W/(m ² K)		$U_{Wall} = 0.13$ W/(m ² K)		$U_{Wall} = 0.13$ W/(m ² K)	
					
$\Psi_{install}$	W/(m K)	$\Psi_{install}$	W/(m K)	$\Psi_{install}$	W/(m K)
Top	0.018	Top	0.028	Top	0.018
Left	0.015	Left	0.024	Left	0.016
Right	0.015	Right	0.024	Right	0.016
Bottom	0.028	Bottom	0.038	Bottom	0.028
$U_{W,installed} = 0.84$ W/(m ² K)		$U_{W,installed} = 0.85$ W/(m ² K)		$U_{W,installed} = 0.84$ W/(m ² K)	

¹ Includes $\Delta U = 0.22$ W/(m² K). Determined through 3D FEM simulation

² Standard value. Glass carrier type: Non-metallic glass carrier with screws

